



DISPOSAL OF GASES

GIA 019/14

Gas Industries Association

7th Floor, Ceejay House, Dr. Annie Besant Road, Worli, Mumbai – 400018, INDIA.
Tel : +91 22 40323960/3195 Fax : +91 22 40323191
Email : giasecretariat.lg.in@linde.com
Internet: <http://www.gasassociation.in>



DISPOSAL OF GASES

GIA VERSION WAS REVIEWED BY:

Prabuddha Dhar	Linde India Ltd.
B. Haribabu	INOX Air Products Ltd.
Chandan Dey	Praxair India (P) Ltd.
Sunil Kher	Air Liquide India Holding (P) Ltd.

Disclaimer

All publications of GIA or bearing GIA's name contain information, including Codes of Practice, safety procedures and other technical information that were obtained from sources believed by GIA to be reliable and/ or based on technical information and experience currently available from members of GIA and others at the date of the publication. As such, we do not make any representation or warranty nor accept any liability as to the accuracy, completeness or correctness of the information contained in these publications.

While GIA recommends that its members refer to or use its publications, such reference to or use thereof by its members or third parties is purely voluntary and not binding.

GIA or its members make no guarantee of the results and assume no liability or responsibility in connection with the reference to or use of information or suggestions contained in GIA's publications.

GIA has no control whatsoever as regards, performance or non performance, misinterpretation, proper or improper use of any information or suggestions contained in GIA's publications by any person or entity (including GIA members) and GIA expressly disclaims any liability in connection thereto.

GIA's publications are subject to periodic review and users are cautioned to obtain the latest edition.

Table of Contents

1	Introduction	1
1.1	Scope.....	1
1.2	Purpose.....	1
1.3	Key operations for safe container disposal.....	1
2	Training and safety in the disposal of gases	2
2.1	Training	2
2.2	Training procedure	2
2.3	Training scope.....	2
2.3.1	Product knowledge	2
2.3.2	Container knowledge.....	2
2.3.3	Selection of a disposal method	2
2.3.4	Operation of disposal plant/equipment.....	3
2.3.5	Personnel safety.....	3
2.4	Safety - design of plant and equipment.....	3
2.5	Safety checklist.....	3
3	Selection of a disposal method	4
3.1	Introduction	4
3.2	Gas characteristics	4
3.3	Local conditions, regulatory requirements and operational constraints	4
3.4	Quantity of gas	5
3.5	Disposal checklist.....	5
3.6	References.....	5
4	Methods of disposal.....	5
4.1	Introduction	5
4.2	Index to methods.....	5
4.3	Methods	6
4.3.1	Method 1- Recycling of gases	6
4.3.2	Method 2 - Disposal of gases by absorption/adsorption/reaction	6
4.3.3	Method 3 - Disposal of gases by burning.....	12
4.3.4	Method 4 - Disposal of gases by venting to the atmosphere.....	16
4.4	References.....	21
5	Gas characteristics and recommended disposal methods	21
5.1	Introduction	21
5.2	Explanatory notes on the table of Annex 1	21
5.2.1	Column 1 Gas name and EC Classification.....	21
5.2.2	Column 2 Key gas characteristics	22
5.2.3	Column 3 recommended disposal methods.....	23
5.2.4	Column 4 key operational and safety considerations.....	23
5.3	References.....	23
6	Disposal of gas mixtures.....	23
7	Identification of container contents.....	24
7.1	Introduction	24
7.2	Identification by product name	24
7.3	Identification by colour	25
7.4	Indication by hazard labels.....	25
7.5	Indication by type of container	25
7.6	Indication by type of valve.....	26
7.7	Indication by container markings.....	26
7.8	Confirmation of indications of contents.....	26
7.9	Flowchart for identification of container contents	27

7.10	References	27
8	Disposal of non serviceable containers	27
8.1	Introduction	27
8.2	Notes on ensuring the container is empty.....	28
8.3	Notes on purging containers	28
8.4	Notes on devalving	28
8.5	Notes on potentially hazardous residues	28
8.6	Notes on rendering containers unserviceable.....	29
8.7	References.....	29
9	References.....	29
	Annex 1 - Gas characteristics and recommended disposal methods	31
	Annex 2 - Index to gas names and synonyms	67
	Annex 3 - Index to gas names in English, French, Chinese, Korean and Japanese	77

1 Introduction

1.1 Scope

As a part of a programme of harmonization of industry publications, the EIGA Document 30 was adopted as a future harmonised document for the worldwide use and application by all member companies of the International Harmonisation Council. The 2012 edition incorporates all modifications agreed by the Gas Industry Associations during the harmonisation process. The AIGA 2012 edition (AIGA 083/13 – Disposal of Gases) has the same technical content as the editions from the other regional associations. However, there are editorial changes primarily in formatting, units used and spelling. Also, references to regional regulatory requirements will be different in the various editions.

This document recommends disposal methods for more than 130 gaseous chemicals and their mixtures and provides safe practices for the disposal of their containers when unserviceable. This guide reflects the concern of the industrial gases industry to ensure that when the need arises for disposal of gaseous chemicals and mixtures, standards of health, safety and environmental quality continue to be maintained. Only environmentally acceptable methods are proposed.

This publication compliments the information and data presented in AIGA 018 for the “Safe Handling of Electronic Specialty Gases”

1.2 Purpose

Dealing with damaged and/or unidentifiable containers (gas cylinders, drum tanks and similar transportable and pressurized vessels) is often an integral part of the gas disposal operation, and for this reason guidance on the subject is included. However, such work is potentially dangerous and shall only be performed by experienced personnel.

The compilers of this guide envisage it will be used as an aid in the training of operators involved in the disposal of gases. The sections have been written with this in mind, and in particular summary checklists have been added for use as training modules.

1.3 Key operations for safe container disposal

Key operations are (note, if doubt exists at any stage in the procedure, specialist advice should be obtained.)

- 1) Action: Identify container contents
Reference: Section 7
- 2) Action: Select disposal method
Reference: Sections 4 and 5
- 3) Action: Safely dispose of container contents
Reference: Sections 5 and 6
- 4) Action: Evacuate and/or purge container
Reference: Section 8.3
- 5) Action: Devalve container
Reference: Section 8.4
- 6) Action: Remove any noxious residues from the container
Reference: Section 8.5
- 7) Action: Render cylinder unserviceable and scrap
Reference: Section 8.6

2 Training and safety in the disposal of gases

2.1 Training

It is essential that all personnel engaged in the disposal of gases shall be properly trained and equipped and their practical competence established before they engage in disposal work. In specific cases, local certification can be required.

In some instances the emphasis is on using 'experienced operators', and it is important to understand that this guide assumes that the operator's experience has also been reinforced with systematic and recorded training.

It is recommended that all operators undertaking gas disposal work should

- be properly trained in practice and theory;
- have written instructions/checklists;
- be properly equipped with protective clothing and safety equipment; and
- be provided with correctly designed disposal plant and equipment, and, if expected to deal with emergency situations, be trained to assemble emergency rigs from readily available materials.

2.2 Training procedure

Training shall be based on written instructions and procedures, and shall be carried out by a competent person. The training program should be a blend of theory and practice, and it is recommended that each phase of training be recorded and signed off on completion, by both the trainer and the trainee. Refresher training at predetermined intervals should also be given.

Whilst this guide has been compiled in such a way as to assist the writing of training programs, it is strongly recommended that those responsible for gas disposal functions compile specific and detailed operational procedures for their own activities, and ensure that operators are given checklists which they can use as an aide-memoire during the disposal work.

2.3 Training scope

It is recommended that training programs should include:

- product and container knowledge, including identification of contents
- principles of disposal method selection
- disposal procedures
- personal protection and general safety
- risk assessment.

2.3.1 Product knowledge

The training program should provide operators with:

- an understanding of the general properties of gases
- a more detailed understanding of the physical and chemical properties of the specific gases they are handling, and particularly their hazardous properties.

The legally required safety data sheets (MSDS/SDS) shall be available and used during the training.

2.3.2 Container knowledge

Training should include:

- basic knowledge of the containers and how to handle them safely
- key features of valve design and the purpose of any safety devices fitted
- identification of cylinder contents.

2.3.3 Selection of a disposal method

Even where operators have the disposal method prescribed, it is recommended that they understand the principles of selecting a disposal method.

2.3.4 Operation of disposal plant/equipment

Training shall be carried out in conjunction with written procedures, which shall include coverage of all foreseeable/potential hazards.

Safe handling methods of any chemical reagents, and the disposal of any resultant spent chemicals or by-products should also be included.

Emergency procedures in the event of spillage, leak, fire, etc, should be considered, documented and practiced.

2.3.5 Personnel safety

For training in personnel safety to be effective it shall be supported by written, clear, practical and authoritative rules on the use of protective clothing and equipment.

Protective clothing and equipment likely to be covered in the training are:

- eye and face protection;
- breathing equipment;
- head protection;
- body protection (chemical resistant and or flame retardant clothing, safety shoes, gloves);
- hearing protection;
- gas monitors; and
- any other Personal Protective Equipment (PPE) that could be required to handle the materials.

The operator shall also be trained in the understanding and use of installed safety features such as special ventilation systems, fire prevention/fire fighting equipment and gas monitoring systems.

2.4 Safety - design of plant and equipment

Proper design of plant and equipment is a prerequisite for safe operation.

Key features to check are:

- the design shall be carried out by a competent person and should be checked by someone other than the designer;
- risk assessment shall be carried out;
- all pipes and vessels shall be designed to contain any pressure likely to be experienced - and the design and working pressures should be known by the operating operator; and
- all materials used shall be compatible with the gases to be dealt with.

2.5 Safety checklist

- Are the methods and procedures written down and approved?
- Are the written procedures available in the working area?
- Has the equipment been properly designed - particularly for materials compatibility and pressure?
- Are adequate warning notices displayed and is the area restricted to authorized personnel?
- Are emergency procedures prepared and understood?
- Has the operator been formally trained, and has the training been recorded?
- Has the operator the correct protective equipment/clothing, and been trained to use it?
- Should breathing apparatus be available? If yes, is it functioning correctly, properly located, and is the operator trained?
- Are trained First Aiders and First Aid equipment available?
- Have adequate preparations been made for treatment of persons exposed to the gases being handled?
- If highly toxic and or corrosive gases requiring specialist medical treatment are being handled, have the local medical services been informed?
- Are medical treatment protocols available for the products being disposed of?
- Is the MSDS/ SDS available for the product to be disposed of?
- Is the disposal system capable of handling the quantity and type of gases to be treated?
- Are spent chemicals appropriately segregated and disposed of according to their properties?

Note: Operators shall not admit gases for disposal into the disposal system without first establishing the compatibility of the gas with the disposal system and the capacity and performance of the system. A 'waste basket' approach is prohibited on grounds of safety.'

3 Selection of a disposal method

3.1 Introduction

There are many disposal methods available. It is the responsibility of the operator to follow documented procedures to select the best possible method for the condition that exists.

It is important when disposing of a gas that new safety problems are not created. For instance it is of little value to dispose of a gas by burning if the products of combustion sent to the atmosphere are just as toxic as or more than the gas being treated. Nor is it helpful if the disposal of a gas by scrubbing results in a chemical equally as toxic and difficult to get rid of as the original gas.

There are four principal methods of disposal listed by order of preference:

- recycling;
- absorption or neutralization (or other chemical reaction/adsorption);
- burning or incineration; and
- venting to the atmosphere.

These methods are further detailed and described in Section 4.

In Section 5 and Annex 1 recommendations are made for the methods of disposal of all gases listed.

When selecting a method there are three important considerations:

- the characteristics of the gas being treated
- the local conditions, regulatory requirements and operational constraints
- the quantity of gas to be disposed of.

For most gases several methods are recommended, and the person responsible for the disposal operation shall select a method and prepare instructions taking local conditions, regulatory requirements and operational constraints into account. When designing equipment and selecting disposal methods, due care and attention should be exercised.

Venting to the atmosphere by dilution should be avoided for gases which cannot be vented in pure form because of environmental considerations.

3.2 Gas characteristics

It is essential that the operator is fully aware of the main characteristics of the gases they are dealing with. Of particular importance will be, if they are toxic, flammable, oxidizing, harmful or corrosive. Each of these characteristics will dictate which methods of disposal are practical and effective.

Other characteristics which will need to be known are whether the gases have any warning properties by smell or sight, what materials they are compatible with and which materials are prohibited, whether the gases are liquefiable or permanent, and the possible reactions with the atmosphere.

Information on the physical properties is also important. Density of the gas relative to air, the boiling point and vapour pressure should be known when dealing with liquefied gas.

Because certain key gas characteristics are so important to the disposal operation, they have been listed in the gas table in Annex 1. More information on the gases shall be obtained from the MSDS/ SDS of the suppliers and from the documents referenced in 3.6

3.3 Local conditions, regulatory requirements and operational constraints

Whilst the fundamental requirement not to damage the environment is of overriding importance, it shall still be acknowledged that local conditions will affect the choice of method used. Where disposal has to take place in the midst of other activities, the precautions will of necessity be more stringent than when disposal is carried out in an open and isolated region. In the former case weather conditions can also play a part. Precautions could have to be taken when windless and inversion conditions prevail.

Whilst this guide has tried to take into account normal local and national regulations, it is the responsibility of the operator to ensure awareness of and compliance with all regulations and legislation applicable to the location.

3.4 Quantity of gas

Quantity of gas to be disposed of is an important consideration, but normally where the operation is an on-going routine one, the choice of method for the quantities involved will be quite obvious.

3.5 Disposal checklist

Considerations when choosing method of disposal:

GAS CHARACTERISTICS	LOCAL CONDITIONS AND CONSTRAINTS	QUANTITY (Kg)
Toxic? Flammable? Oxidant? Corrosive? Pyrophoric? Harmful to the environment? Warning properties? Pressure/vapour pressure? Liquefiable/compressed? Boiling point Density relative to air? Compatible materials? Combination of the above?	Space available? Other activities in vicinity? Weather conditions? Availability of expertise and equipment? Condition of container and valve? Local/national regulations?	Small? Medium? Large?

3.6 References

[1, 2, 3, 4]

4 Methods of disposal

4.1 Introduction

This section describes the basic principles of the four disposal methods, i.e. by recycling, by absorption or by reaction, by burning and by venting to the atmosphere. Recovery and recycling of the gases should be considered in all cases provided it is safe to do so.

Each disposal method is named and detailed under the following headings:

- 1 Schematic arrangement of the disposal method
- 2 Description of method
- 3 Application
- 4 Equipment design
- 5 Operation
- 6 Operational precautions

4.2 Index to methods

	Section
<u>Method 1</u> Recycling of gases	4.3.1
<u>Method 2</u> Disposal of gases by absorption or by reaction	
2A Direct discharge into simple scrubber	4.3.2.1
2B Discharge into counter-flow scrubber	4.3.2.2

2C	Discharge into solid-state absorber	4.3.2.3
<u>Method 3 Disposal of gases by burning</u>		
3A	Direct combustion - gas phase	4.3.3.1
3B	Combustion/incineration - liquid phase	4.3.3.2
3C	Incineration - gas phase	4.3.3.3
<u>Method 4 Disposal of gases by venting to the atmosphere</u>		
4A	Direct discharge from container valve	4.3.4.1
4B	Direct discharge from container valve into fume cubicle or hood	4.3.4.2
4C	Controlled release through vent line	4.3.4.3
4D	Controlled dilution in forced air stream	4.3.4.4

4.3 Methods

Note: Do not dispose of flammable or oxidant gases as mixed batches of cylinders.

4.3.1 Method 1- Recycling of gases

General principles: This is not a disposal method, as usually understood, but a technique for reclaiming residual gases and returning them safely to suitable containers for re-use.

As a solution to dealing with residual gases it is strongly recommended both in the interests of the environment, and the conservation of materials and energy. Recycling is a particularly favoured technique when dealing with high value gases, or gases that are expensive to dispose of due to their nature or because of the quantity involved. Most recovered product has to be re-processed and purified before being re-used, and the cost of such treatment shall be taken into account when considering a recycling system.

It shall be stressed that recycling of gaseous chemicals is best carried out by the supplier of the material who will have the necessary product handling and container filling expertise. On no account shall material be returned to a container without the written authority of the owner of the container. The owner shall specify, or have agreed, the method, equipment and procedures to be used.

Different transfer methods can be used. Liquefiable gases can be transferred to the recovery container in the liquid phase either by pressurizing the container to be emptied with a compatible inert gas, by pumping or by creating a vapour pressure gradient.

Permanent gases can be recompressed into the recovery container using a gas compressor or by liquefying the gas cryogenically into a suitable cryogenic receiver. It is important to ensure that any carbon steel container or pipework is not used in contact with cryogenic liquids as they can become brittle at temperatures lower than -20°C. The cryogenic liquid is then allowed to warm and the resultant gas passed into the recovery container.

When recycling gases care shall be taken to ensure that the product to be recycled is not contaminated with any material that could have a detrimental effect on the safety of the operation or subsequent use of the recycled material. Care shall be taken when recovering liquefied gases that the recovering vessel will not be overfilled or exceed the ADR filling ratio. For gases that could polymerize or that can decompose ensure that the product is pure, stable or contains sufficient amount of stabilizer.

4.3.2 Method 2 - Disposal of gases by absorption/adsorption/reaction

General principles: Disposal of certain reactive gases can be achieved by absorption/reaction in a liquid (scrubbing) or by adsorption in a solid state medium. The resultant solution and/or suspension or other absorption product should be less harmful and more conveniently disposed of than the original waste gas.

This method can be used in conjunction with methods where harmful combustion products are evolved.

The choice of absorption/reagent medium and equipment used will depend on a number of factors including:

- reactivity of the absorption medium with the waste gas;
- quantity of waste gas to be disposed of and frequency of disposal operations; and
- ease of treatment of the spent absorption medium.

These factors shall be considered when selecting absorption/reagent medium and absorption method.

4.3.2.1 Method 2A - Direct discharge into simple scrubber

2A.1 – Schematic arrangement

- | | |
|---|----------------------------------|
| 1. Shingle (packing medium) | 5. Non return valve |
| 2. Absorbent chemical (reacting chemical) | 6. Inlet gas purge (if required) |
| 3. Sight glass | 7. Pressure control indicator |
| 4. Flow control valve | 8. Suckback trap |

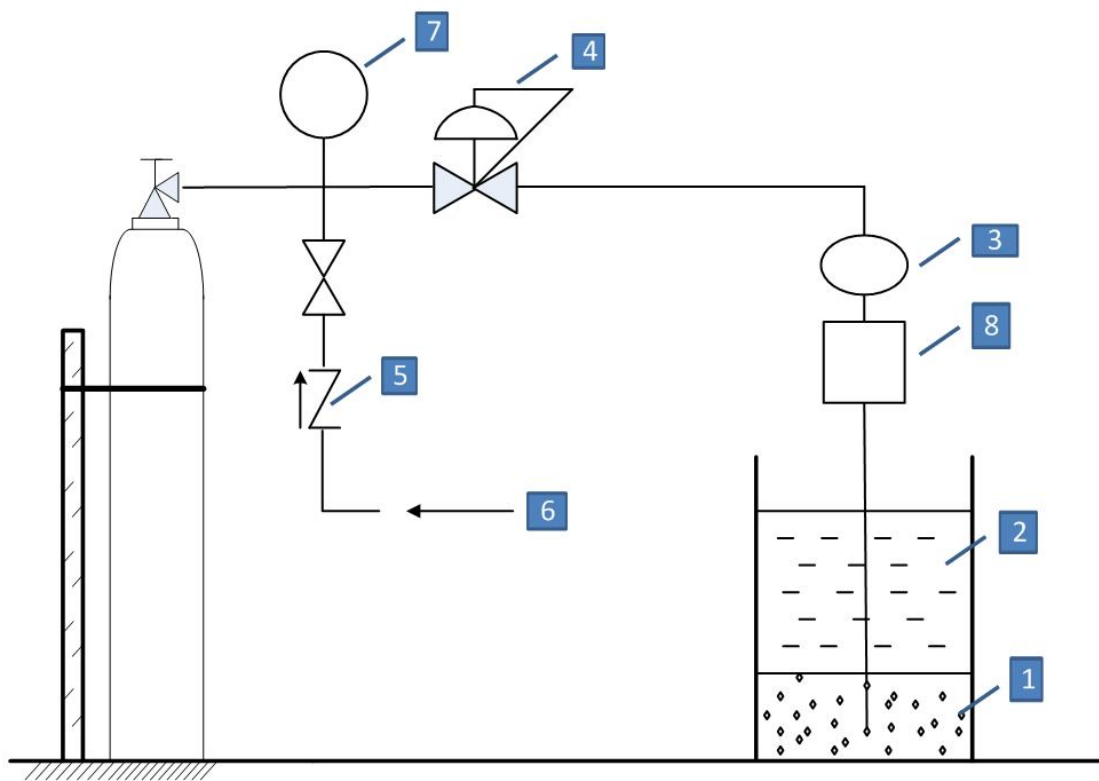

2A.2 Description of method: The gas to be disposed of is fed directly into the absorbent chemical. Under certain circumstances, liquefied gas may be fed into the scrubber in the liquid phase following a risk assessment.

2A.3 Application: This method is recommended where absorbent chemical is available that strongly and readily absorbs the gas or reacts with it. Simplicity and portability can favour the choice of this method under emergency conditions. This method should be restricted to gases that are not Acute Toxic Cat.1 ($LC50_{rat.1h} < 200ppm$) or Acute Toxic Cat.2 ($LC50_{rat.1h} < 1000ppm$) nor Carcinogenic, Mutagenic or Reprotoxic because of the risk of exposure to the release of non-reacted toxic gas.

2A.4 Equipment design: Equipment should be kept as simple as possible and should be suitable for the required working pressure and compatible with the gas and the absorbent chemical. It is desirable to maximize the contact of the waste gas with the absorbent chemical. This can be achieved by

constricting the end of the pipe dipping into the absorbent chemical (to reduce the gas bubble size) and/or by submerging the pipe in a layer of coarse sand at the bottom of the scrubber vessel.

A flow control system (incorporating a pressure regulator if necessary) should be installed in the waste gas feed to enable the gas flow to be matched to the capacity of the scrubber or by use of a sparger.

A 'suckback trap' or a 'vacuum breaker' should be incorporated in the line before the scrubber pot. A sightglass or length of transparent pipe may also be installed between the regulated waste gas supply and scrubber to indicate 'suckback' conditions. A continuous inert gas purge also reduces the risk of suckback.

2A.5 Operation:

Purge air from the system with an inert gas if the gas or gas mixture is flammable

Check that the flow control valve is closed.

Open the waste gas supply valve and adjust pressure regulator as appropriate (if fitted).

Slowly open the flow control valve until the scrubber capacity is achieved (i.e. maximum flow rate compatible with complete waste gas absorption).

Renew the absorbent chemical as necessary. Dispose of spent scrubber chemical safely according to national legislation.

When the disposal operation is complete (or when renewing absorbent chemical), close the waste gas supply valve. Purge the system with inert gas (where installed) and close the flow control valve.

2A.6 Operational precautions:

This operation should be carried out in a well ventilated or open area.

Ensure that the absorption/reaction is taking place effectively and safely throughout the disposal operation. Constant vigilance is necessary to ensure no blockage, breakthrough, overheating or chemical suck back occurs.

Particular attention shall be paid to personal protection when handling reactive absorbent chemicals (such as caustic or acids).

Ignition sources (including open flames, electrical equipment and static discharge) should be excluded if the waste gas is flammable or if flammable gases can be produced. Care should be taken to avoid build-up of potentially explosive flammable gas/air mixtures in and around the system. The temperature of the chemical should be checked to avoid a hazardous situation arising. The capacity of the absorption/reaction vessel and the quantity of chemical shall be sufficient to absorb all of the gas to be discharged.

4.3.2.2 Method 2B - Discharge into counterflow scrubber

2B.1 – Schematic arrangement

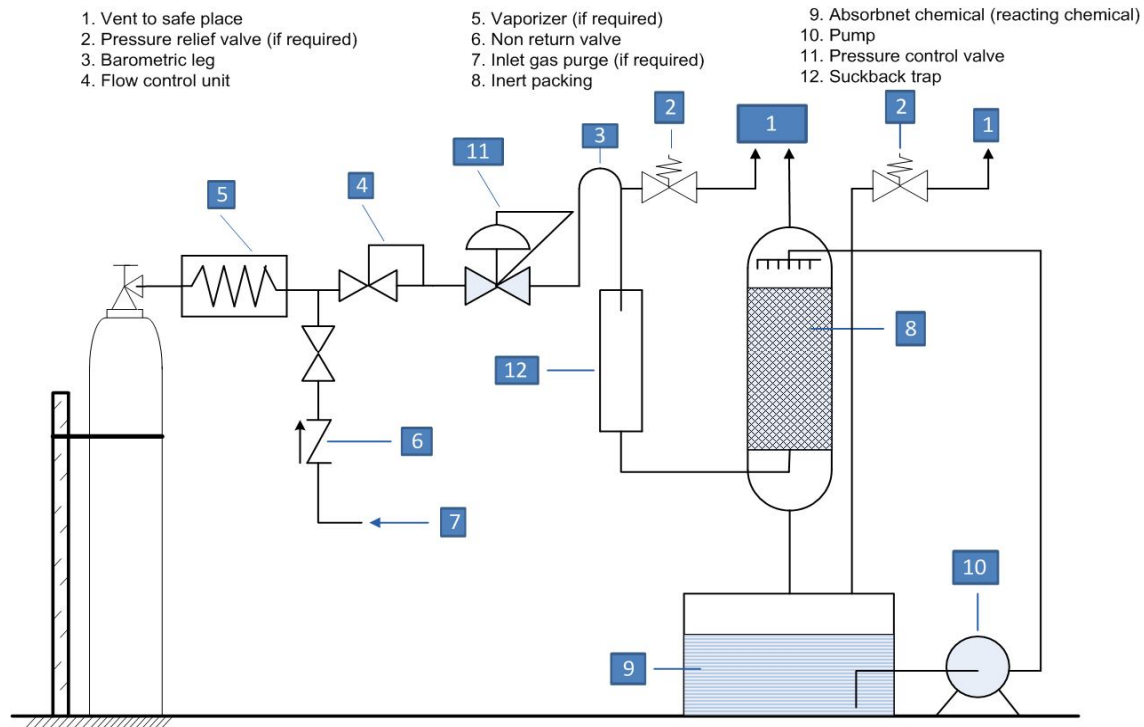

2B.2 Description of method: The gas to be disposed of is fed into the counterflow scrubber. The gas can be fed directly as illustrated. The source of gas can also be a fume cubicle or hood (see method 4B) or an incinerator, see method 3C). Under certain circumstances, liquefied gas in its liquid phase can be fed into the counterflow scrubber following a risk assessment, but note that the pipework configuration shown in 2B.1 is not suitable for this.

2B.3 Application: This method is recommended where a suitable absorbent or reacting chemical is available and where there is an on going disposal requirement.

2B.4 Equipment design:

Equipment should be specifically designed by a competent person for its intended service. Materials of construction should be compatible with the gas and absorbent chemical. Due account should be taken of operating pressures and possible temperature rises from reaction between the gas and absorbent chemical. Pumping alkaline absorbents present special problems. Pumps may have to be running continuously to prevent the shaft sticking to pump housing.

Suitable arrangements should be made to ensure the system is monitored and shut down in the event of waste gas 'breakthrough'. To ensure safe and efficient performance, consideration should be given to monitoring the following:

- waste gas input flow;
- efficacy of absorbent chemical (e.g. pH);
- concentration of waste gas in scrubber vent; and
- temperature of absorbent chemical.

A 'barometric-leg' should be installed in the supply line to the scrubber to minimize the risk of absorbent chemical sucking back.

Consideration can also be given to the provision of an anti-suckback device (such as a liquid interceptor vessel fitted with level switch actuating a solenoid valve).

A flow control system (incorporating a pressure regulator if necessary) should be installed in the waste gas feed to enable the gas flow to be matched to the capacity of the scrubber.

An inert gas purge facility should be installed.
The scrubber vent should discharge to a safe well ventilated place away from personnel.
Consideration should be given to 'flameproofing' equipment where waste gas is flammable.

2B.5 Operation:

Check scrubber unit is operating correctly, i.e.:

- efficacy of absorbent chemical;
- operation of mechanical units such as recirculating pumps, agitators, fans, etc.; and
- operation of monitoring equipment.

Purge air from the system with an inert gas if the gas or gas mixture is flammable

Adjust the feed rate until correct (specified) waste gas flowrate is achieved.

Unless automatic shutdown arrangements are installed, supervise the disposal operation, correcting flowrate/replenishing absorbent chemical etc., as necessary.

When the disposal operation is complete, purge the system with inert gas and close the flow control valve.

Shut down scrubber system and dispose of spent absorbent chemical safely.

2B.6 Operational precautions:

Ensure that the scrubbing system is operating correctly throughout the disposal operation (either by automatic monitors or by personal supervision).

Ensure that waste gas flowrate and quantity are controlled such that scrubber does not overheat and breakthrough does not occur.

Particular attention shall be paid to personal protection when handling reactive absorbent chemicals (such as caustic or acids).

Ignition sources (including open flames, electrical equipment and static discharge) should be excluded if the waste gas is flammable or if flammable gases could be produced. Care should be taken to avoid build-up of potentially explosive flammable gas/air mixtures in and around the system.

Some gases, especially halogen acid forming gases, form a mist with moist gases which is not readily absorbed by most types of scrubbers. These gases should either be fed to the scrubber in high concentration or diluted with a dry gas to low concentration. The temperature of the chemical (in 9) or in the scrubber (8) should be checked to avoid a dangerous situation arising. The capacity of absorption/reaction of the absorbent/reacting chemical shall be calculated to be large enough for the quantity of gas to be discharged.

4.3.2.3 Method 2C - Discharge into solid-state adsorber

2C.1 – Schematic arrangement

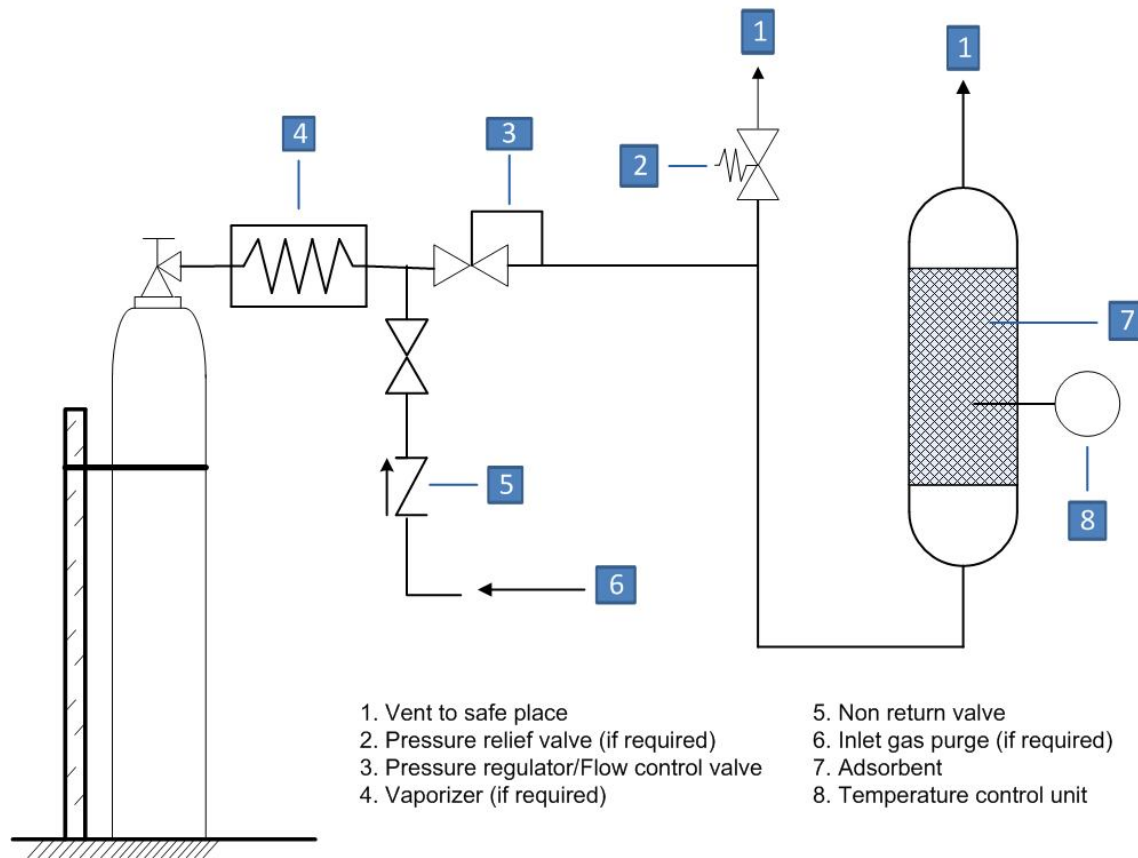

2C.2 Description of method: The gas to be disposed of is fed into a vessel containing a bed of solid adsorbent. The gas can be fed directly as illustrated. The source of gas can also be a fume cubicle or hood (see method 4B or an incinerator, see method 3C).

2C.3 Application: This method is recommended where a solid adsorbent is available which strongly and readily adsorbs the gas. Simplicity and portability of a small solid-state absorber can favour the choice of this method under certain emergency conditions.

2C.4 Equipment design:

Equipment should be constructed from materials compatible with the gas and solid-state adsorbent. Due account should be taken of operating pressures and possible temperature rises from reaction between the gas and adsorbent.

Factors to be taken into account when establishing the size of the solid-state adsorber include:

- required disposal rate
- quantity of waste gas for disposal
- acceptable frequency of changing/regenerating the adsorbent.

These factors will determine the dynamic and static capacity of the chosen adsorbent.

A distribution system should be incorporated in the absorber to ensure good distribution of the waste gas in the bed of adsorbent. Poor waste gas distribution will result in 'channelling' and premature 'breakthrough'.

The adsorbent particle size is an important consideration when establishing the design of a solid-state absorber. Generally, small particles give a high contact area and hence greater absorbing efficiency, however, small particle sizes can lead to clogging or high pressure drops and tendency for 'channelling' through the bed.

Provision should be made to monitor the waste gas input flow and concentration of waste gas in the absorber vent. Consideration should also be given to monitoring the temperature of the absorber and the need for a cooling system.

A flow control system (incorporating a pressure regulator if necessary) should be installed in the waste gas feed to enable the gas flow to be matched to the capacity of the solid-state absorber.

An inert gas purge facility should be installed if practicable.

The solid-state absorber vent should discharge to a safe, well ventilated place away from personnel.

2C.5 Operation:

Purge the system with an inert gas to remove air if the gas or gas mixture is flammable.

Check (as far as practicable) that absorbent is not spent (e.g. from the operating log which records cumulative throughput).

Adjust the feed rate until the correct (specified) waste gas flowrate is achieved.

Unless automatic shutdown arrangements are installed, supervise the disposal operation, monitoring absorber vent for breakthrough and adjusting flowrate as necessary.

When the disposal operation is complete, close the waste gas supply valve. Purge the system with inert gas (where installed) and close the flow control valve.

Dispose of or regenerate solid absorbent safely.

2C.6 Operational precautions:

Ensure that the solid-state absorber is operating correctly throughout the disposal operation (either by automatic monitors or by personal supervision).

Ensure that waste gas flow rate and quantity are controlled such that the scrubber does not overheat and breakthrough does not occur.

Particular attention shall be paid to personal protection when handling reactive solid adsorbents.

Ignition sources (including open flames, electrical equipment, static discharge) should be excluded if the waste gas is flammable or if flammable gases can be produced. Care should be taken to avoid build-up of potentially explosive flammable gas/air mixtures in and around the system. The temperature in the adsorbent (7) should be checked to avoid a dangerous situation arising. The capacity of adsorption/reaction of the adsorbent (7) shall be calculated to be large enough for the quantity of gas to be discharged.

4.3.3 Method 3 - Disposal of gases by burning

General principles: Disposal of certain gases can be achieved by burning or passing through a hot flame. Many flammable gases will burn to form harmless products of combustion. Where toxic products of combustion are formed, these should be dealt with subsequently using one or more of the other methods detailed in this guide.

It is important that flame characteristics are controlled to ensure that the required reaction takes place. It is usually possible to determine flame characteristics by visual observation and/or temperature measurement. Flame control can be achieved by adjustment of the gas flows and/or by addition of an appropriate gas at a controlled rate.

4.3.3.1 METHOD 3A - DIRECT COMBUSTION - GAS PHASE

3A.1 – Schematic arrangement

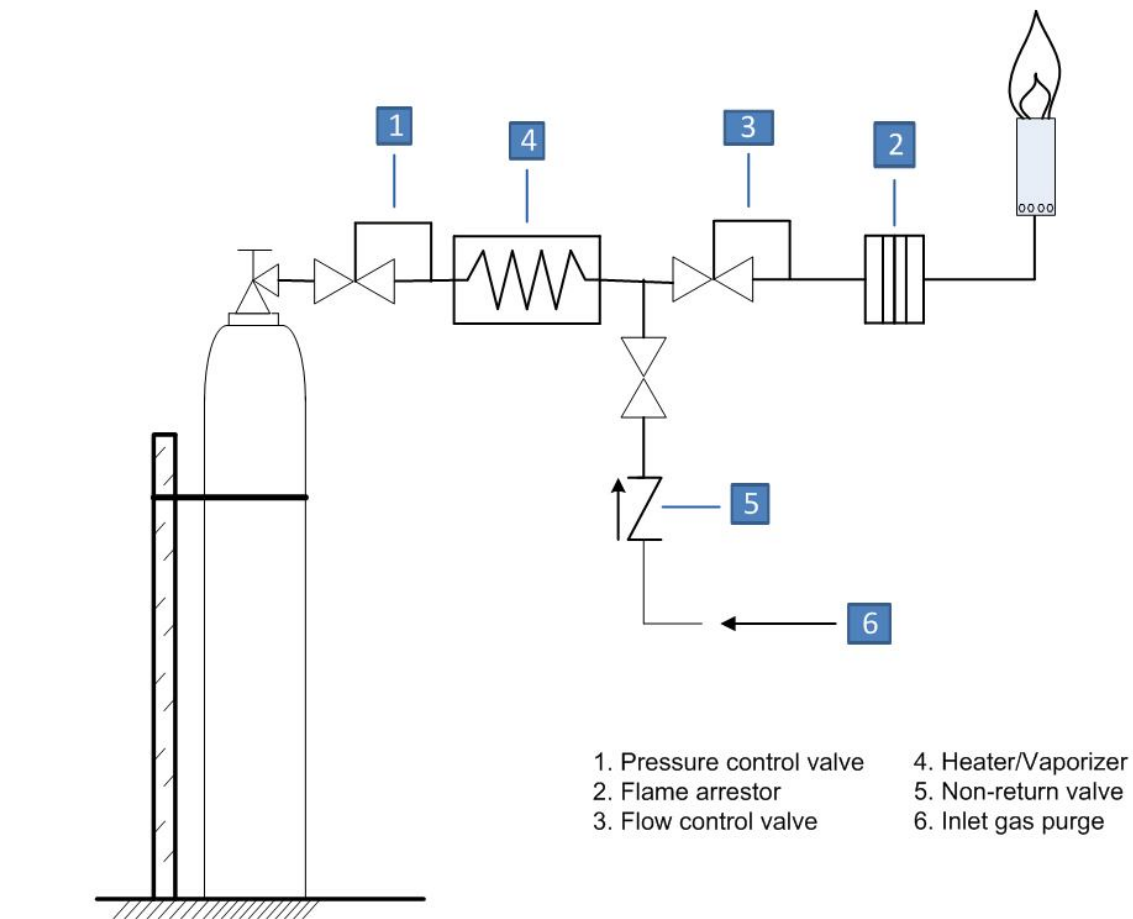

3A.2 Description of method: The gas to be disposed of is fed into the burner and burnt with an oxidant (normally air).

3A.3 Application: This method is recommended for flammable gases which can be burnt completely yielding non-toxic products.

3A.4 Equipment design:

Burner: The fuel gas is usually metered through a jet and mixed with the oxidant prior to burning. The oxidant can be either injected from an external supply under pressure (e.g. a welding torch) or drawn into the fuel gas stream by venturi action (e.g. a Bunsen burner).

Generally, burners which require addition of an oxidant under pressure have a wider application range.

Ignition: Ignition can be achieved either manually (matches, flint gun, etc.) or automatically (piezo crystal, hot wire, pilot flame, etc.). Automatic ignition should be used where practical.

Flow controls: Pressure regulators and flow control valves are normally required to ensure a controlled flame is maintained. Under most circumstances it is desirable to operate the burner with excess oxidant to minimize the formation of 'incomplete combustion' products such as carbon monoxide.

Purge gas: It is recommended to install a 'purge gas' supply, to clear the system of air before use and of flammable gas after use.

Vaporizer: For the rapid disposal of certain liquefiable gases, product may be withdrawn from the liquid phase. (See also Method 3B). Under these circumstances, a vaporizer is usually necessary to ensure only gas is admitted to the burner.

Safety devices: A flame arrester should be fitted to all fuel lines. Where a vaporizer is installed (for liquefied gases) a pressure relief device could be required. A flame sensor system, which shuts off the waste gas in the event of flame failure, should be incorporated.

3A.5 Operation:

Purge air from the system with an inert gas to remove air if the gas or gas mixture is flammable.

Ensuring fuel gas and oxidant flows are correct, ignite flame.

Ensure flame is maintained.

Prior to shutdown, purge system with inert purge gas (where installed).

3A.6 Operational precautions:

Site the burner in a safe position away from combustible material.

Prevent any excessive pressure drop due to the cooling of a liquefied gas being vaporized.

4.3.3.2 METHOD 3B - COMBUSTION/INCINERATION - LIQUID PHASE

3B.1 – Schematic arrangement

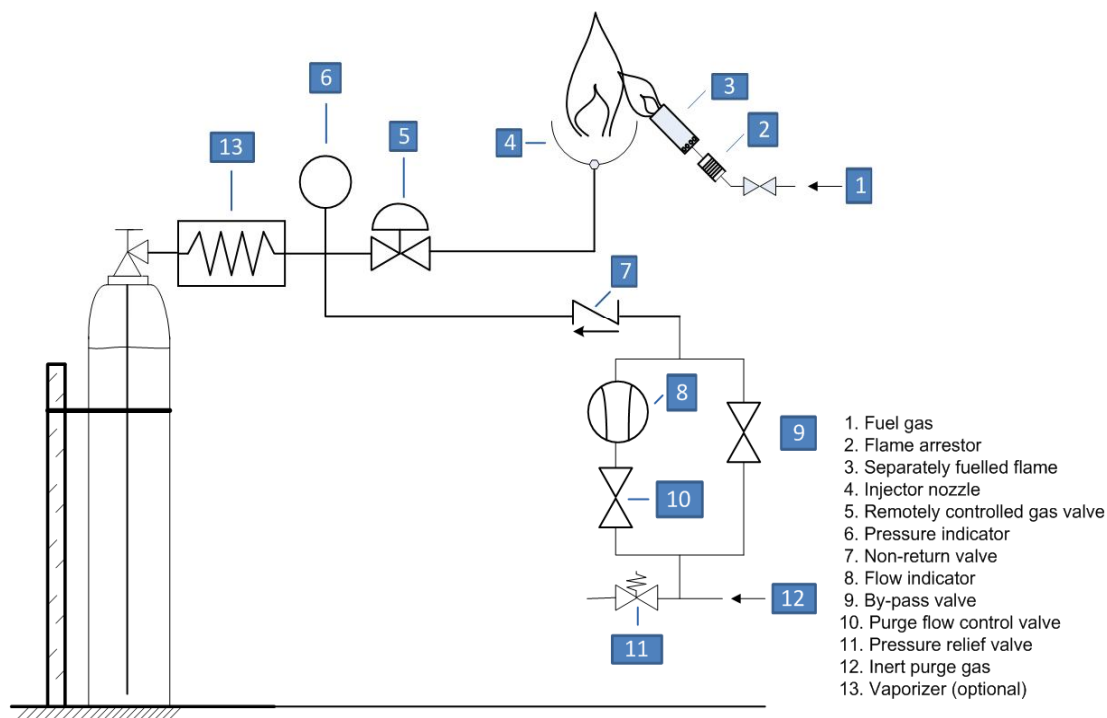

3B.2 Description of method: The waste product is withdrawn from the liquid phase either through a vaporizer or fed as a liquid to the burner and burned in the presence of a separately fuelled flame.

3B.3 Application: This method is particularly useful for rapid disposal of liquefiable fuel gases, especially where they have a low vapour pressure or where contamination of solids or low vapour pressure contaminants are suspected.

This method may be extended to include gases which have an oxygen rich molecule provided a continuous supply of inert gas is added to the product stream during incineration/burning operations. The presence of a separately fuelled flame will aid incineration of poorly combustible liquefied gases/gas mixtures, e.g. 20% ethylene oxide mixtures.

3B.4 Equipment design:

Injector nozzle: This should be designed to limit the flow of waste product (without blockage by impurities/combustion products, etc.) to a level that can be safely and completely combusted.

Separately fuelled flame: This should provide a flame of sufficient size, correctly orientated to the injector nozzle, as to ensure complete combustion of the jet of waste liquid product.

Purge gas: Inert gas for purging the pipe system before and after the disposal operation and for pressurization of the waste product container. The purge gas can also be used to assist in the control of the flame by addition to the waste product stream.

Valve actuation: In certain circumstances, it can be desirable to enable control valves to be operated remotely. Where this is the case, fail-safe pneumatically operated valves should be used.

3B.5 Operation: (See also 2B.I)

Purge air from the system with an inert gas to remove air if the gas or gas mixture is flammable.

Orientate waste product container to enable liquid withdrawal.

Purge air from the system.

It is advantageous (and essential with 100% ethylene oxide, propylene oxide and similar) to provide an inert gas flow into the product stream during burning.

When all the liquid waste product has been burnt, purge the container of residual gas by repeated pressurization with the purge gas (check working pressure of container).

3B.6 Operational precautions:

Site the burner in a safe position away from combustible materials.

Ensure waste product container is adequately pressurized with inert gas during the operation.

Observe special precautions above when dealing with products such as ethylene oxide.

4.3.3.3 Method 3C - Incineration - gas phase

3C.1 – Schematic arrangement

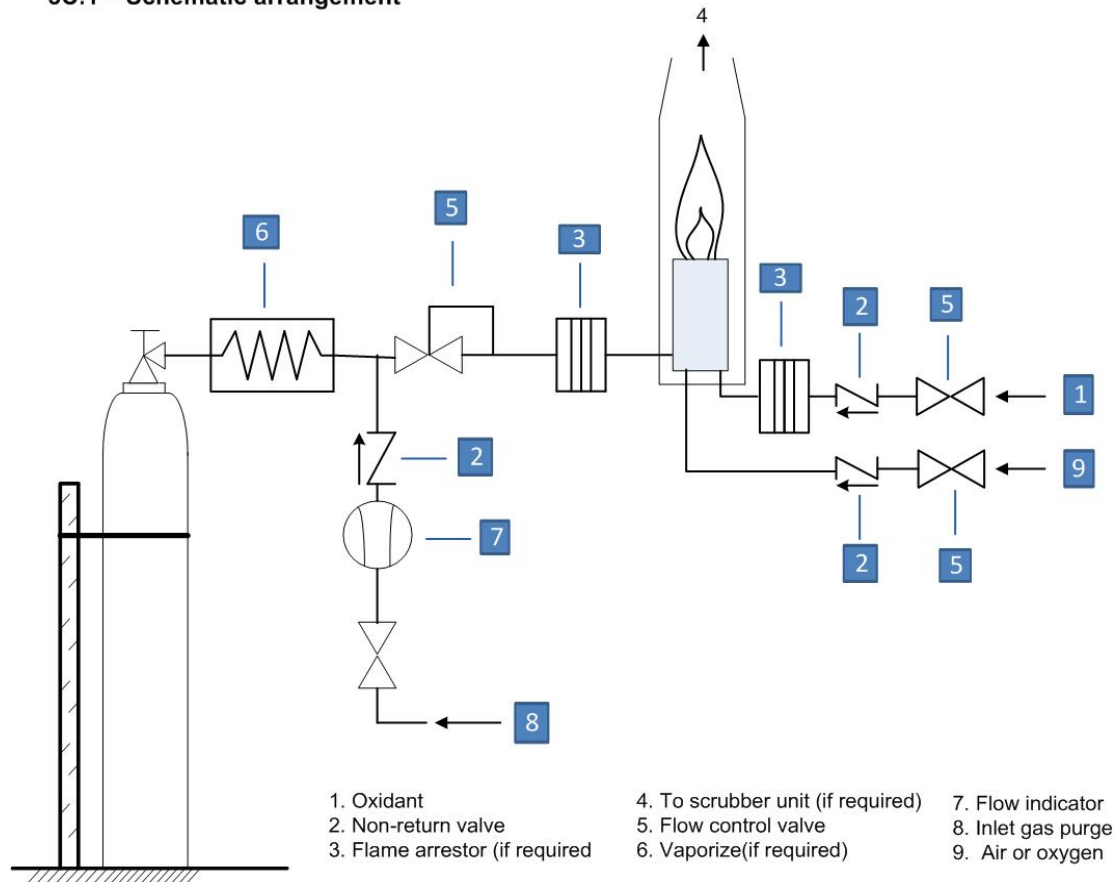

3C.2 Description of method: The waste gas is incinerated in a separately fuelled flame.

3C.3 Application: This method is particularly useful for the disposal of:

- Gases which are non-flammable but can be decomposed in a flame.
- Gases which can be decomposed in a flame but which yield toxic decomposition products which require subsequent treatment.

- Gases where a carefully controlled burning process is advisable.

3C.4 Equipment design:

Burner/Separately fuelled ignitor: A suggested design would comprise a burning nozzle with three concentric channels, waste product flowing through the inner, fuel gas through the middle and oxidant through the outer channel.

Flow control: Pressure regulators and flow control valves are normally required to ensure an optimum ratio of fuel gases to oxidant.

Flue gas cooler: If the flue gases will be subject to further treatment, a flue gas cooler can be required to protect from overheating downstream equipment.

Purge gas: It is desirable to install a purge gas supply. The inert purge gas is used to purge air from the waste gas system prior to introduction of the waste gas. It may also be used to purge the waste gas container and system at the end of incineration operations.

Vaporizer: A vaporizer can be useful when dealing with low pressure liquefiable gases. Product is withdrawn from the liquid phase and passed through the vaporizer to ensure only gas is admitted to the burner.

Safety devices: A flame arrestor should be fitted to all fuel lines. Where a vaporizer is installed (for liquefied gases) a pressure relief device could be required.

3C.5 Operation:

Purge air from the waste gas system using inert purge gas.

Ignite the separately fuelled flame and adjust.

Carefully open the waste gas supply, observing the flame and increasing the oxidant feed as required by the waste gas combustion. Optimize the waste gas combustion but ensure a stable flame is maintained.

To shut down, close the waste gas supply container valve. Purge the waste gas system with inert gas (purge gas to pass through the separately fuelled ignitor flame). If empty, the waste gas container can also be purged an appropriate number of times to dilute its residual contents. Close the oxidant and separate fuel gas supplies. Ensure all flames are extinguished.

3C.6 Operational precautions:

Site the burner in a safe position away from combustible materials.

Prevent any excessive pressure drop due to the cooling of a liquefied gas being vaporized.

In certain cases, the burning conditions shall be very carefully controlled, otherwise toxic products of combustion formed can be difficult to remove (e.g. in the case of ammonia and amines, if oxidant levels are too high, excessive amounts of toxic oxides of nitrogen can be produced. These can prove difficult to scrub.)

4.3.4 Method 4 - Disposal of gases by venting to the atmosphere

General principles: In this method, the waste gas is diluted with air to a harmless concentration.

This is a most convenient and economical method, but clearly it shall be carried out in a responsible manner to ensure that no hazardous conditions are created, legislative requirements are met and there is no risk of damage to the environment. As pointed out earlier venting to the atmosphere by dilution should be avoided for gases which cannot be vented in pure form because of environmental considerations.

Disposal to atmosphere may be direct from the cylinder valve for non-flammable and non-toxic gases or through a vent pipe, or through forced draught ducting.

4.3.4.1 Method 4A – Direct discharge from container valve

4A.1 – Schematic arrangement

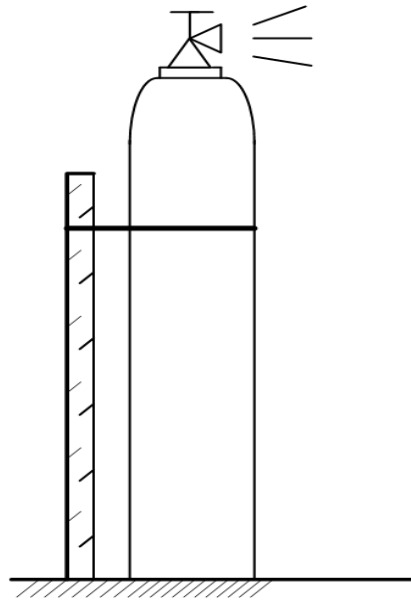

4A.2 Description of method: Gas is discharged directly from the container valve to the atmosphere.

4A.3 Application: The method is limited to non-flammable, non-toxic or non-corrosive gases or mixtures.

4A.4 Equipment design: All that is required is a means of opening the container valve. The container should be positively supported.

4A.5 Operation: The container valve is opened slowly to permit gas discharge at an appropriate rate.

4A.6 Operational precautions: The operation should be carried out in a well ventilated area away from incompatible processes, air intakes, and away from persons not engaged in the disposal operation. Consideration should be given to prevailing meteorological conditions to ensure safe dispersion of vented gases.

Noise level should be controlled to meet local regulations.

4.3.4.2 Method 4B - Direct discharge from container valve into fume cubicle or hood

4B.1 – Schematic arrangement

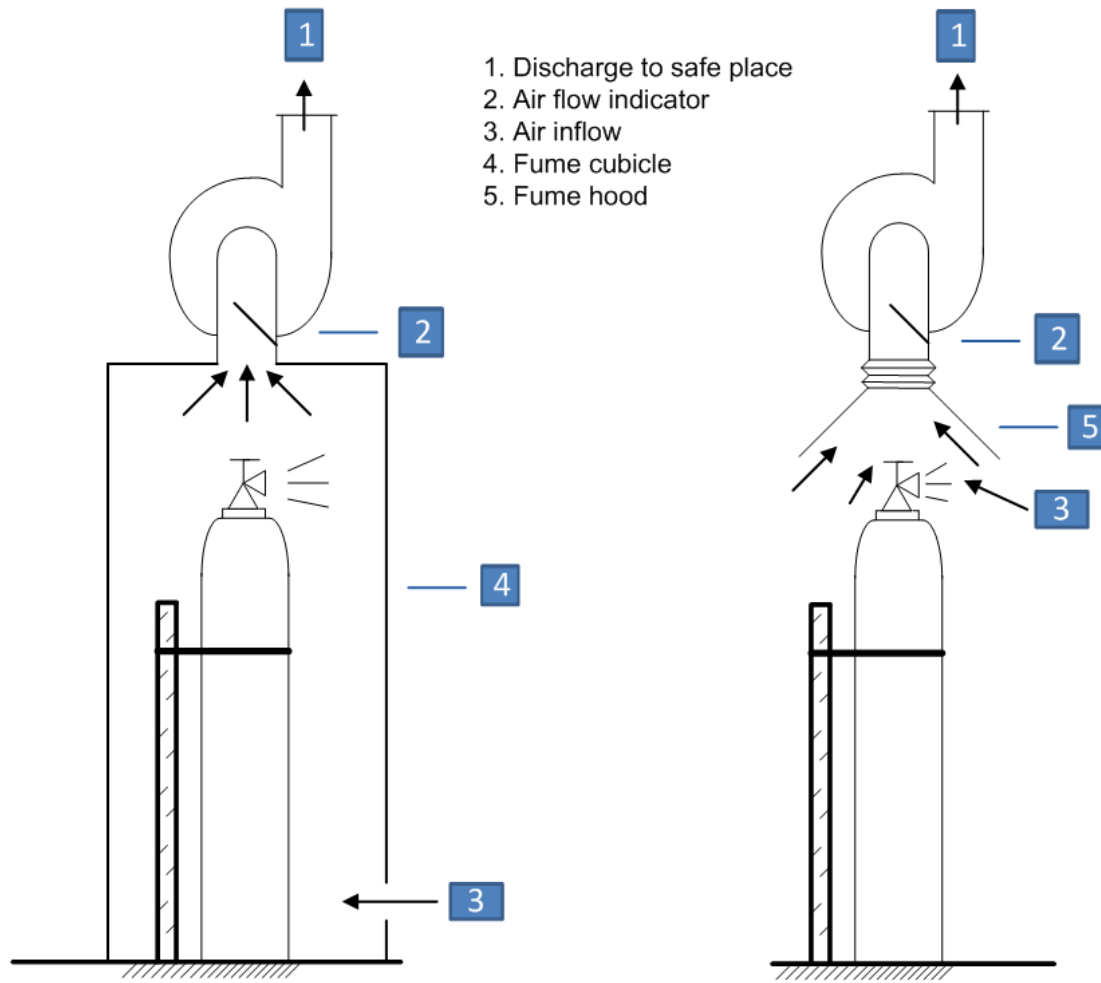

4B.2 Description of method: Gas is discharged directly from the container valve into a fume cubicle or hood. Dilution with air is achieved and the exhaust from the fume cubicle or hood is discharged to a safe place (normally at high level).

4B.3 Application: The method can be used for the disposal of a wide range of gases. It is of high practical value and is widely used. It is particularly useful when dealing with leaking containers or where a disposal operation is required from inside a building.

4B.4 Equipment design: A suitable hood to fit over the container valve or a cubicle into which the container can be placed. Air is extracted from the hood or cubicle and discharged to a safe place (usually at high level) away from persons and from incompatible processes and air intakes. The container should be positively supported.

4B.5 Operation: The container is placed in a fume cubicle or the fume hood is placed over the container valve. The container valve is opened slowly to permit gas discharge at the appropriate rate. Where a fume cubicle is used, the door(s) or air inlet shall be adjusted to obtain the required air velocity and flowrate for complete gas entrainment.

4B.6 Operational precautions: If the cylinder content is flammable, only a limited flow of gas shall be disposed of in this way. Ignition sources (including open flames, electrical equipment, static discharge) shall be excluded.

Checks shall be made to ensure that equipment is operating correctly, especially that air flow is maintained throughout the disposal operation.

Consideration should be given to prevailing meteorological conditions to ensure safe dispersion of vented gases.

If the method is used to dispose flammable gases, the flowrate of the dilution gas has to be calculated to assure, that the resulting concentration of the flammable gas in the exhaust flow is lower than 50% of its LEL.

4.3.4.3 Method 4C - Controlled release through vent line

4C.1 – Schematic arrangement

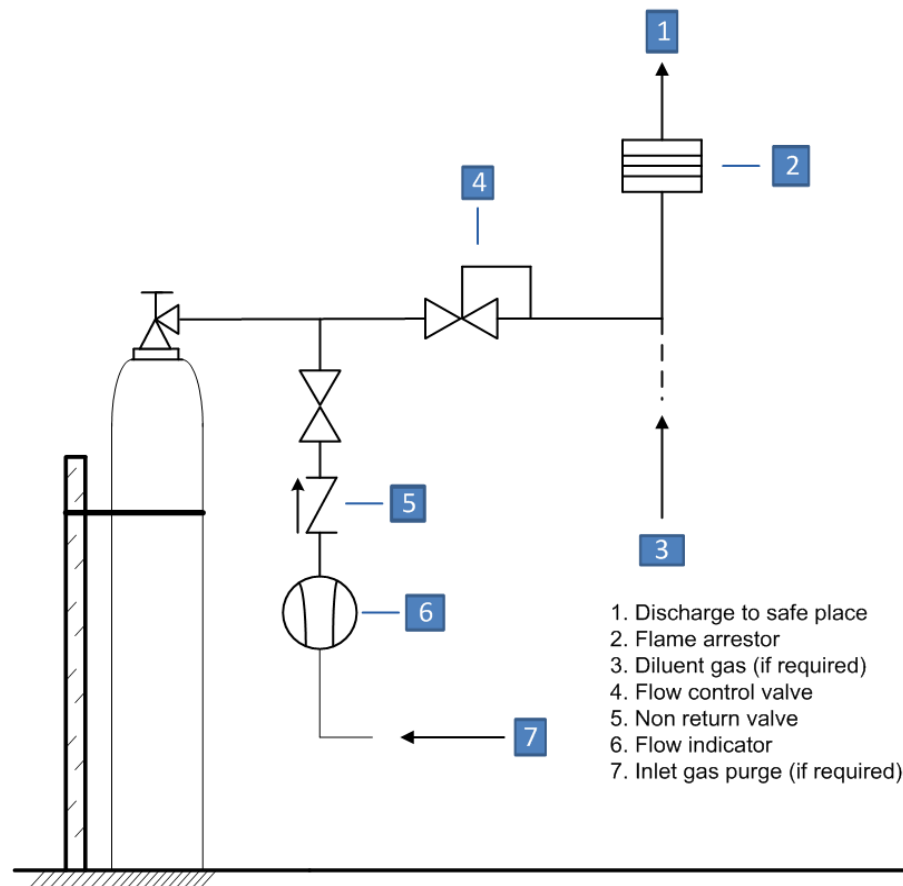

4C.2 Description of method: Gas is discharged to atmosphere via a vent line terminating in a safe place (usually at high level). Dilution with inert gas is possible if required.

4C.3 Application: This method can be used wherever there is a good reason to discharge the gas away from the gas source (e.g. where the gas source is in a confined space).

4C.4 Equipment: The vent line shall discharge to a safe place (usually at high level) away from persons and from incompatible processes and air intakes.

It is necessary to install a flow control system in the vent line (i.e. regulator and flow control valve). Where the system is to be used for the disposal of toxic or flammable gases, an inert gas purge should be installed. A suitable flame arrestor should also be incorporated when flammable gases are discharged. If a dilution gas is required, it should be fed into the vent line after the gas flow control system. The container should be positively supported.

4C.5 Operation: The container is connected to the vent line. If the container content is flammable, air should be purged from the vent line by introduction of inert gas. The vent line should be purged after discharge of toxic or flammable gases before disconnecting the cylinder.

4C.6 Operational precautions:

Ignition sources (including open flames, electrical equipment, static discharge) should be excluded if the content of the container is flammable.

Consideration should be given to the rate of disposal in relation to prevailing meteorological conditions to ensure safe dispersion of vented gases.

If the method is used to dispose flammable gases, the flowrate of the dilution gas has to be calculated to assure, that the resulting concentration of the flammable gas in the exhaust flow is lower than 50% of its LEL.

4.3.4.4 Method 4D - Controlled dilution in forced air stream

4D.1 – Schematic arrangement

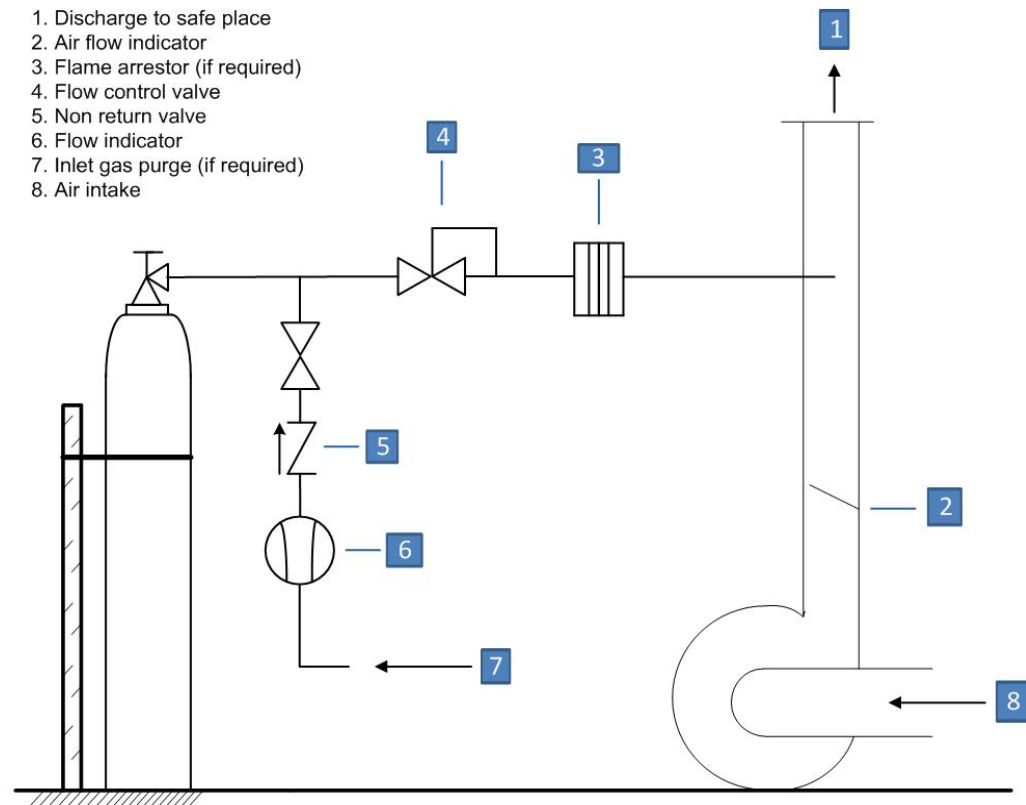

4D.2 Description of method: Gas is discharged at a controlled rate into a forced air stream. The diluted air/waste gas mixture is then discharged to a safe place (normally at high level).

4D.3 Application: This method can be used for all gases, including toxic, which do not harm the environment. The rate of discharge of some gases can however be low owing to the high levels of dilution required.

4D.4 Equipment design: A pipe is connected from the container via a flow control system into a forced air stream designed to ensure adequate mixing of the waste gas with air. A venturi system can be used as an alternative to that shown in 4D.1. The dilute waste gas/air mixture is discharged to a safe place (usually at high level) away from persons and from incompatible processes and air intakes. Where the system is to be used for the disposal of toxic or flammable gases, an inert gas purge

should be installed. A suitable flame arrestor should also be incorporated when flammable gases are discharged.

To enable the level of dilution to be measured and controlled, flowmeters should be installed in both the waste gas pipe line and air stream.

4D.5 Operation: The container is connected to the disposal system.

If the container content is flammable, air should be purged from the system with an inert gas such as nitrogen.

A positive check is made to ensure the air draught is functioning correctly.

The container discharge shall be controlled within a predetermined maximum flowrate.

The maximum container discharge rate is set to ensure that an acceptable dilution is reached before the point of discharge of the system to atmosphere.

Factors to be taken into account when establishing the maximum container discharge rate are:

- the nature of the gas or gas mixture;
- the throughput of the forced air system; and
- the position of the discharge point and the local conditions and regulations.
-

After discharge of toxic or flammable waste gases the system should be purged with inert gas (such as nitrogen before disconnecting the container.

4D.6 Operational precautions:

Ignition sources (including open flames, electrical equipment, static discharge) should be excluded if the content of the container is flammable.

Care should also be taken to avoid build-up of potentially explosive flammable gas/air mixtures in and around the system.

Care should be taken to ensure that set discharge rates are not exceeded and that the forced air system is functioning correctly.

Consideration should be given to prevailing meteorological conditions to ensure safe dispersion of vented gases.

If the method is used to dispose flammable gases, the flowrate of the dilution gas has to be calculated to assure, that the resulting concentration of the flammable gas in the exhaust flow is lower than 50% of its LEL.

4.4 References

[1, 2, 4]

5 Gas characteristics and recommended disposal methods

5.1 Introduction

The purpose of this section is to make recommendations for the range of disposal methods available for each of the gases listed in Annex I. The final choice will depend on:

- the quantity of gas involved;
- the local conditions and circumstances; and
- the availability of equipment (see Section 4).

5.2 Explanatory notes on the table of Annex 1

The following notes refer to the table headings and should be read and understood before using the table.

5.2.1 Column 1 Gas name and EC Classification

Gas name

The gases are listed in alphabetical order. Where difficulty is found in locating a particular gas, reference should be made to the alphabetical index in Annex 2, which includes synonyms and translations.

EC Classification

The classification according to the Globally Harmonised System of the United Nations (UN-GHS) is shown. In Europe, the UN-GHS has been implemented in the CLP Regulation 1272/2008. When not officially classified in Annex VI of the CLP Regulation, the classification proposed by EIGA is given (see ref. 5). Gases are classified according to the different hazard classes and categories identified by the UN-GHS. In the table of Annex I, only hazard categories for physical hazards and acute health and environmental hazards have been identified according to the following table. As less relevant for the choice of disposal method the other hazards classes and categories have not been identified.

	Physical hazards
F1	Flammable Gas Category 1
F2	Flammable Gas Category 2
O	Oxidising Gas
	Acute health hazards
T1	Acute toxic gas, category 1
T2	Acute toxic gas, category 2
T3	Acute toxic gas, category 3
T4	Acute toxic gas, category 4
C1	Skin corrosive gas, category 1
C2	Skin irritation gas, category 2
	Acute environmental hazard
N1	Aquatic acute and chronic 1

Note: Gases that are non-flammable/non-oxidising and with no acute health or environmental hazards are identified as A for Asphyxiating.

5.2.2 Column 2 Key gas characteristics

This column sets out the key physical and chemical characteristics of each gas, in order of importance to the disposal operation.

The information is presented as concisely as possible so that it can be readily assimilated if required quickly. It is also intended to assist in the first stages of assessing permanent disposal arrangements. Where more comprehensive technical data and specialist expertise is needed, refer to Section 9 for gas data references.

The terms used to describe the gas characteristics are explained in more detail below:

Asphyxiants:

The insidious and sudden danger of gases marked ASPHYXIAN cannot be too strongly emphasized. These gases, although not toxic nor corrosive, shall never be allowed to accumulate in work places, or indeed in any space where it is possible for persons to enter.

Toxicity: The classification of gases for acute toxicity into hazard categories is based on the LC50 value for one hour or four hours exposure of rats. The gases are allocated to the hazard categories according to the table below.

<u>LC50.rat/1h (ppm)</u>	<u>LC50.rat/4h (ppm)</u>	<u>Hazard Category of Acute Toxicity</u>
≤ 200	≤ 100	Category 1
>200 to ≤ 1 000	>100 to ≤ 500	Category 2
>1 000 to ≤ 5000	>500 to ≤ 2500	Category 3
>5000 to ≤ 40 000	>2500 to ≤ 20 000	Category 4

To indicate the severity of toxicity the LC50 value is also given.

Flammability: The upper and lower percentage limits (by volume) of flammability in air are shown. These are taken from the Safety Data Sheets from various sources. Whenever flammable gases are being handled, personnel shall be made aware of the need to avoid the formation of explosive or flammable mixtures with air, and the requirement to eliminate all sources of ignition except where combustion is planned and controlled.

Relative Density (RD): The approximate density of each gas relative to air, so that the operator can readily judge the degree of difficulty in dispersing the gas.

Vapour pressure and boiling point: Values given are sufficiently accurate for guidance when handling the gas/liquid.

Vapour pressures (vp) are expressed as bar-gauge unless otherwise stated.

Boiling points (bp) are at atmospheric pressure.

Critical temperatures are shown for liquefied gases when less than 25°C.

Warning properties: 'Warning Properties' refer to the ability to detect the gas by the human senses (for example, smell and sight).

5.2.3 Column 3 recommended disposal methods

Under this heading recommended disposal methods are given which are set out in detail in Section 4. Other disposal methods can be used providing that a risk assessment demonstrates the impact on safety and the environment is acceptable. All disposal methods shall comply with local regulatory requirements.

5.2.4 Column 4 key operational and safety considerations

Under this column attention is drawn to key safety information. Data on compatible materials suitable for use in the construction of disposal equipment are given, together with concise information on chemical reactions and particular reactive hazards. Also included are hazards particular to the gas concerned, and materials which should be avoided.

5.3 References

[1, 2, 3, 4, 5]

6 Disposal of gas mixtures

This publication addresses the disposal of pure gases used in the industries including the electronic industry. It is recognised that mixtures of these pure gases are also used. Some guidance is now provided on how to handle a problem cylinder that contains a mixture of one or more of these components in a balance gas.

Some guidance for the disposal of compressed and liquefied gas mixtures can be obtained from Section 4 by consulting the recommendations given for each constituent.

The Safety Data Sheet of the mixture should be consulted to establish the chemical, physical and toxicological properties of the mixture.

However, it shall be noted that:

(a) In some instances, the hazards of some of the constituent gases can be reduced by the effect of dilution by other gases in the mixture.

(b) In some instances, hazards can be other than shown because of the presence of more than one reactive gas.

It is essential therefore to be aware firstly of the constituent gases and their proportions in the mixture, and secondly of the characteristics of the resultant mixture. With this information, a suitable disposal method can be chosen.

Further points for consideration are:

Toxic components: Can be of a sufficiently low concentration to permit the use of a simpler method (such as method 4) than that recommended for the individual component gases.

Flammable components: Can be of a sufficiently low concentration as to render the mixture non-flammable and permit the use of a simpler method (such as method IA) than that recommended for the individual component gases. Mixtures containing low concentration flammable gases can require incineration as simple burning may not work.

Oxidants: The oxidant potential of the mixture shall be taken into account, especially where equipment is being used for a multiplicity of disposal applications. Oxidants should be purged from systems using an inert gas (such as nitrogen) before and after introduction of flammable gases.

Pressure: The pressure of the mixture shall be established. Compared with the normal cylinder pressure of the component, which determines the disposal method, the mixture cylinder pressure can be substantially higher. Other types of pressure reducing devices could be necessary.

Container evacuation: This is frequently required after disposal of the container's content to atmospheric pressure. Where evacuation is necessary, consideration shall be given to the treatment of the exhaust gas from the vacuum system. It can also be desirable to install an inert gas supply into the vacuum system to enable complete removal of all traces of the mixture from the container.

Note: Certain components can leave low vapour pressure contaminants in the container which cannot be evacuated.

Cautionary Note: Diborane and diorama mixture cylinders for example when emptied of their content often have a residual coating of higher boranes on the internal surface and base of the cylinder. These higher boranes are extremely unstable and will react violently with many chemicals including water and weak solutions of hydrogen peroxide.

Polymeric residues of diborane can be removed by the use of solvents.

Dioxane may be used for the first wash of a devalved cylinder. The solvent shall be added slowly and with extreme caution. Further washes with Iso-propyl alcohol (IPA) can be necessary to remove all traces of polymer in conjunction with agitation with an abrasive bead such as alumina pyramids. The wash liquors obtained require careful handling/disposal.

References: [1, 2, 3, 4]

7 Identification of container contents

7.1 Introduction

The gas industry as a whole is careful to ensure that the contents are properly identified. Normally, operators will be dealing with containers that they are familiar with and whose contents are well identified.

From time to time, however, operators will be faced with unfamiliar containers. These can come from another country or from another supplier or in extreme cases, could have been stored for long periods under poor conditions leading to the loss of readily obvious means of content identity.

The purpose of this section of the guide is to guide the operator towards positive identification of the container content, even when obvious labelling etc. has been lost.

7.2 Identification by product name

The Gas Industry and most legislative authorities now agree that the name of the gas shall be the primary method of identification. Methods of identifying the content include one or more of the following:

- permanent engraving or stamping of the container (usually on the shoulder or on a shoulder plate) with the gas name or chemical formula or both;
- stencilling of the container with the gas name;

- application of a durable label attached (usually) to the valve end of the container; and
- attachment of a label or tag to the cylinder valve.

Thus the first identification step is to look for such a marking and if one is found, check that it is compatible with all other information that is known about the container.

Sometimes the product can be found to be marked with an unfamiliar synonym, or in a foreign language, and this can be a problem if the chemical formula is missing. In these circumstances refer to Annex 2, the multi-language gas index which includes synonyms.

Refer also to Annex 3 for names in English, French, Japanese, Chinese and Korean.

Care shall be taken using this form of identification that the conclusion as to the content of the cylinder is correct. It is not uncommon during the life of a cylinder that the product it contains will change. This means that there could be several different product name stampings on the cylinder all of which should be over stamped except the last product service name. Over a period of time the over stamping may not be clear potentially causing confusion as to the product in the cylinder.

7.3 Identification by colour

Colours are widely used to identify products contained, but this shall be regarded as a secondary aid to product identification, the primary identification being by the written name (see 7.2 above).

The shortcomings of the colour identification of contents are:

- There is a wide range of custom and practice throughout the world, so that the markings of a container moving across a border can give a totally erroneous indication of contents to the operator used to a different colour marking system, and
- Whilst it is possible to cover most of the standard gases with a unique colour coding, there is a practical limit to the colours and colour combinations available so that it is impossible to have a unique colour coding for all gaseous chemicals and mixtures of gaseous chemicals. Cylinders sometimes have received many coats of paint during their lifetime. When cylinders have been left for an extended period of time the final coat of paint could have deteriorated and been lost completely from the cylinder. Care shall be taken when using colour for establishing the content of a cylinder due to this potential issue.

7.4 Indication by hazard labels

International transport agreements or regulations (IMDG/ICAO/ADR/RID) require suppliers to affix hazard labels which indicate the hazard properties (flammability, corrosivity, toxicity etc.) of the content. These give guidance to the type of gas contained and will also eliminate a wide range of gases which will not come into the category covered by the hazard label.

7.5 Indication by type of container

Examination of the type of container can again reduce the range of possible contents.

For example, as a general rule, low pressure welded containers will usually contain low pressure liquefiable gases, and high pressure seamless containers will usually contain high pressure permanent or liquefiable gases (there could, of course, be exceptions).

Material of construction of the container can also be a guide - at least by eliminating gases incompatible with the material.

7.6 Indication by type of valve

Many countries have legislation or codes of practice specifying valve outlet connections and pressure relief for various gases. Often, gases are grouped by chemical and physical properties for the purpose of valve outlet designation.

The relevant standards and codes of practice both from national authorities and from the supply companies should be available. For Europe, refer to IGC DOC 97 "Valve outlet connections for gas cylinders"

The material and pressure rating of the valve can eliminate a whole range of gases, thus assisting with the identification.

When dealing with difficult instances of identification of containers, the condition of the valve outlet could be a guide to the gases contained. Observation and analysis of deposit at the valve outlet will assist.

7.7 Indication by container markings

Normally the container is permanently marked with the name of the owner, and contact with the owner can establish details of the contents. If this fails, there should also be the manufacturers mark and a serial number, and this again can be used in difficult instances to help identify the filler and thus the contents of the container.

7.8 Confirmation of indications of contents

In the absence of positive identification, it has been seen above that an indication of contents could be obtained from colour, from hazard labels, from the type of container and type and condition of valve and from information supplied by the container owner or manufacturer. It is still important, having obtained such guidance to the likely contents, to confirm those indicators by relating them to the pressure in the container, the weight of the contents (assuming the tare weight of the container can be established) and by carrying out a check on the general chemical and physical characteristics of the contents.

Once identification has been positively established, it is possible to go forward with choosing a disposal method and carrying it through.

In the event of failure to identify and confirm the contents of a container, the container shall be referred to a specialist disposal facility. Details of specialist facilities will be obtainable from major compressed gas suppliers.

7.9 Flowchart for identification of container contents

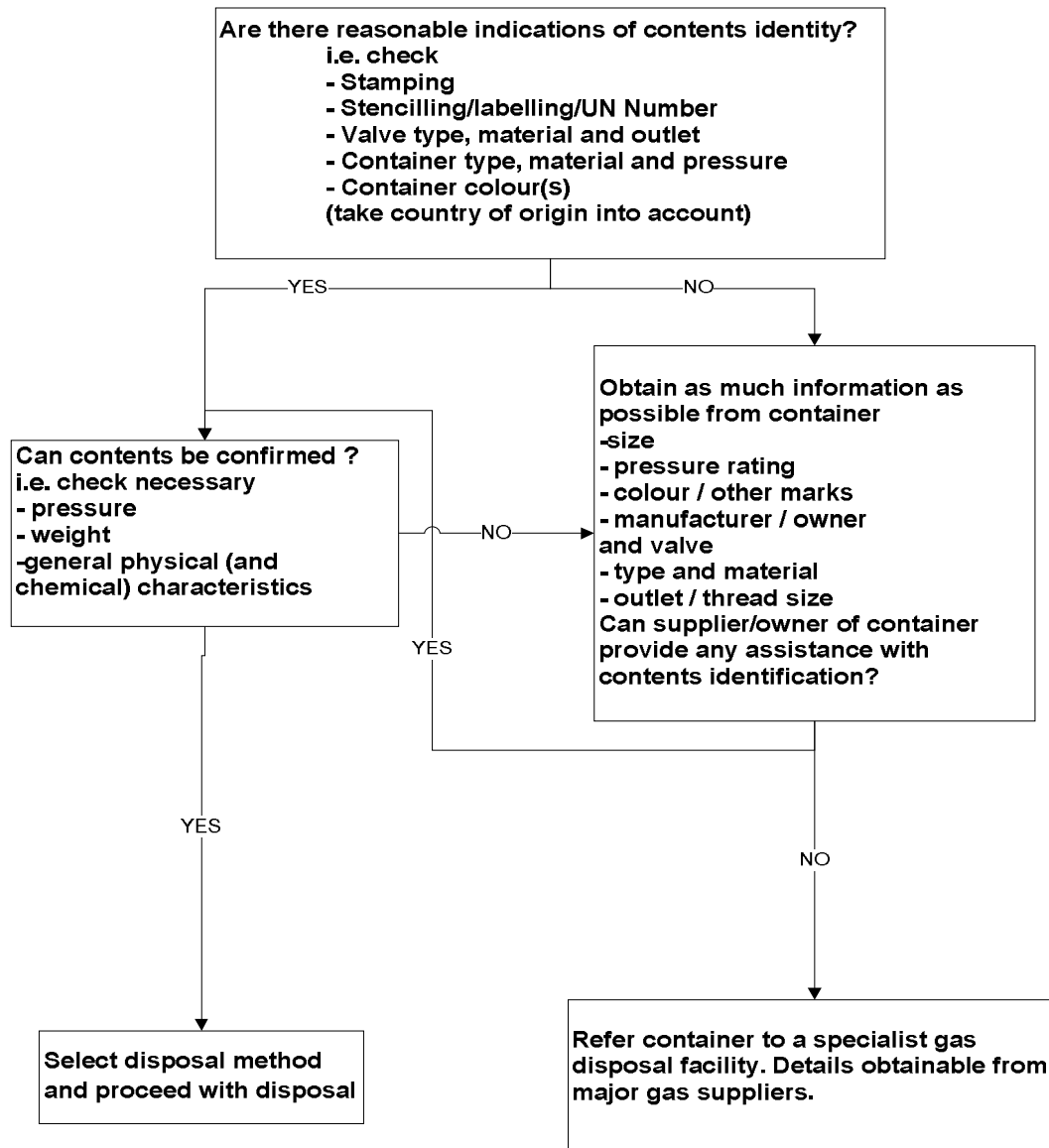

7.10 References

[1, 2, 4, 5]

8 Disposal of non serviceable containers

This section covers the disposal of cylinders and containers once they have been emptied of product and purged.

8.1 Introduction

There are several industry publications on the subject of container disposal (see 8.7 for references.). Each facility disposing of gas containers shall implement written devalving and purging procedures based on industry standards. This section, whilst covering the key points of safe container disposal, is primarily concerned with the provision of practical guidance on the problems that can arise when

dealing with certain gases and gaseous chemicals. It is therefore recommended that this section is studied in conjunction with one of the industry codes on this subject.

Note that this section excludes the disposal of dissolved acetylene containers where special requirements (beyond the scope of this section) apply.

8.2 Notes on ensuring the container is empty

Containers shall not be devalved until a positive check has been made to ensure the container is empty. The following should be noted.

All gases: A check should be made to ensure the container valve (and any attachment such as siphon tube) is clear of obstruction. This can be achieved by introducing a low pressure (say 0.2 bar gauge) of a suitable gas (such as nitrogen) into the container and checking that it is subsequently discharged. In the case of toxic and flammable gases, this check may be incorporated into the purging procedures.

Corrosive/reactive gases: Ensure the valve or dip pipe is not blocked by corrosion/reaction products. Check that no 'suckback' of water or other reaction chemical has occurred by weighing the container (the container could appear empty by pressure check). Where it is suspected that such contamination is present, refer to Section 8.5.

Liquefiable gases: Ensure the container has warmed up to ambient temperature (discharge of the gas phase of a liquefiable gas will result in a lowering of the liquid phase temperature such that the vapour pressure could decrease to atmospheric pressure). In cases of doubt, check that the container is empty by weighing and comparing it to the stamped tare weight of the cylinder.

Gases subject to polymerization: Check that the container is empty by weight. Such gases (especially ethylene oxide) can form a polymer membrane, inside the container, under which liquid can remain.

8.3 Notes on purging containers

So called 'empty' vessels that have contained toxic or flammable gases can still be potentially hazardous because of the residual gas remaining at atmospheric pressure or slightly elevated pressure.

The residue (at atmospheric or slightly elevated pressure) should be removed by inert gas purging (such as nitrogen) and/or evacuation of the container. The extent of purging and evacuation required will depend on the properties of the gas. For example a flammable gas or low toxicity gas container could only require minimal purging to render it safe, whereas a highly toxic gas container could require repeated purging/evacuation cycles before being considered safe to devalue.

8.4 Notes on devalving

Before devalving a container, the operator shall ensure:

- That it is depressurized by carrying out the check described in 8.2 immediately prior to devalving.
- That any residual toxic or flammable gases are at a safe concentration as a result of purging: There shall be adequate controls on the operation (such as a system of certification that purging has been carried out where appropriate).
- That due account has been taken of the possibility of non-gaseous residues which could be potentially hazardous (see Section 8.5).

8.5 Notes on potentially hazardous residues

Containers that have contained certain toxic, corrosive or liquefiable gases can also contain potentially hazardous solid or liquid residues, even after the container has been emptied, purged and devalved. Some residues will be found by visual inspection whilst others shall be assumed to exist because of

the nature of the contained gas. Such residues should be removed before the container is destroyed and sent for scrap. Some examples of typical residues that can be encountered and notes on their removal are given as follows:

Oily residues: All containers should be checked for excessive oily residues. These can usually be removed by washing with a suitable solvent followed by purging.

Salts and corrosive residues: These can be encountered when dealing with vessels that have contained acid or alkaline gases. Such residues can usually be removed by washing with water (hot water in some cases).

Polymers: These can be found in containers that have polymerisable products such as ethylene oxide, butadiene etc. Such polymers can usually be broken down by prolonged soaking with water or by the use of solvents. Polymers of diborane can only be removed by the use of solvents (see Precautionary Note in 6)

Toxic metal oxides: containers that have contained metal hydrides (such as arsine, hydrogen selenide, hydrogen telluride, stibine, germane etc) shall be assumed to contain toxic oxides or other decomposition products. These can usually be satisfactorily removed with an oxidizing acid solution.

Cyanide residues: These shall be assumed for containers that have contained cyanides and can be removed with a suitable alkaline solution.

Cautionary Note:

The decontamination of cylinders which have contained cyanides shall only be undertaken by trained industry experts following a detailed risk assessment. Consideration shall be given to:

1. The residual pressure in the cylinder and possible reaction of hydrogen cyanide with the steel cylinder to liberate hydrogen.
2. The highly toxic nature of any cyanide residues.
3. The personal protective equipment (PPE) and apparatus required to safely remove and treat the cyanide residues.
4. The availability of cyanide antidotes and first aid/medical support during disposal activities.

Care should be taken to ensure the safe disposal of all chemicals etc. used for the removal of potentially hazardous residues from containers (particularly concerning cyanides)

8.6 Notes on rendering containers unserviceable

Where containers are considered unsuitable for further service, they should be rendered unserviceable before sending them to scrap merchants etc. This is to prevent subsequent 'illegal' use (which could be extremely hazardous and, in the event of an incident, could reflect on the original owner of the container). Rendering unserviceable includes one or more of the following:

- cutting the container into pieces
- burning a hole in the container (preferably on the shoulder)
- destroying the valve threads.

8.7 References

[6, 7, 8, 9, 10]

9 References

- 1 Encyclopedie des gas (Encyclopaedia of Gases), L'Air Liquide, Ed., Amsterdam: Elsevier 1976 (also on line at <http://encyclopedia.airliquide.com/encyclopedia.asp?languageid=11&GasID=&CountryID=19>)
- 2 Handbook of Compressed Gases, 4th Ed. (Compressed Gas Association, Ed.), New York: Van Nostrand 1990 (under revision)

- 3 Matheson Gas Data Book, 7th Edition., 2001, McGraw-Hill Professional
- 4 Ent W. L. and Lindenmoyer, H. E.: Safe Handling of Gas Cylinders, Indust. Res. 20(2), 1970, 118 - 122
- 5 EIGA Doc 169 Classification and labelling guide according to the CLP Regulation,
- 6 ISO 6406 Periodic inspection and testing of seamless steel gas cylinders
ISO 10460 Periodic inspection of welded carbon steel gas cylinders
ISO 10461 Periodic inspection of seamless aluminium alloy gas cylinders
- 7 EIGA Doc 129 (AIGA 025) Pressure receptacles with Blocked or Inoperable Valves,
- 8 CGA-P-38 Guidelines for devalving cylinders
- 9 ISO 25760 Operational Procedures for the safe removal of valves from gas cylinders
- 10 EIGA INF.18/11: Devalving Gas Cylinders

Annex 1 - Gas characteristics and recommended disposal methods

1 Gas EC classification	2 Key characteristics	3 Disposal method	4 Key operational/safety consideration
Acetylene C ₂ H ₂ F1	Flammable, 2,3 - 81 % in air Subject to exothermic self decomposition Gas in cylinder is dissolved in solvent/porous mass Poor warning properties Density similar to air	Recycling, 1 Direct combustion, 3A Incineration, 3C Controlled release, 4C	Avoid copper, silver and mercury Use steel, wrought iron or brass containing less than 70 % copper Flashback arrestor shall be used C ₂ H ₂ + 2,5 O ₂ → 2 CO ₂ + H ₂ O (Methods 3A and 3C)
Ammonia NH ₃ F2 T3 C1 N1	Harmful, LC _{50/1 h} = 4000 ppm Flammable 15,4- 28 % in air Liquefied gas, bp ca - 35 °C, vp ca 8 bar Vapour 1,7 x lighter than air Good odour warning	Recycling, 1 Discharge to scrubber, 2A or 2B	Avoid copper, tin, zinc, mercury and Viton Beware suckback of water NH ₃ + H ⁺ → NH ₄ ⁺ (Methods 2A and 2B)
Argon Ar A	Asphyxiant No warning properties Gas 1,5 x heavier than air	Recycling, 1 Direct discharge, 4A Direct discharge, 4B Controlled release, 4C	Use common materials
Arsenic pentafluoride T1	Very toxic, LC _{50/1 h} = 20 vpm Liquefied gas, bp ca. - 53°C, vp ca. 10 bar Vapour 3 x heavier than air	Recycling, 1 Discharge to scrubber, 2B	In the event of eye or skin contact, immediately wash with copious amounts of water Use nickel, Monel, heavy gauge mild steel Use hard rubber, PVC for moist gas AsF ₅ + 8 OH ⁻ → AsO ₄ ³⁻ + 5 F ⁻ + 4 H ₂ O
Arsenic trifluoride T1	Very toxic, LC _{50/1 h} = 20 vpm Liquid, bp ca. 63°C,	Recycling, 1 Discharge to scrubber, 2B	In the event of eye or skin contact, immediately wash with copious amounts of water Use nickel, Monel, heavy gauge mild steel, use hard rubber, PVC for moist gas AsF ₃ + 6 OH ⁻ → AsO ₃ ³⁻ + 3 F ⁻ + 3 H ₂ O

1 Gas EC classification	2 Key characteristics	3 Disposal method	4 Key operational/safety consideration
Arsine AsH_3 F1 T1 N1	Very toxic, $\text{LC}_{50/1\text{h}} = 20$ vpm Poor warning properties (garlic odour) Fast acting, irreversible, systemic poison Flammable, 9-78 % in air Toxic products produced by burning Liquefied gas, bp ca. -62°C , vp ca. 14 bar Vapour 3 x heavier than air	Recycling, 1 Discharge to scrubber, 2B Direct discharge to solid-state adsorber, 2C Dilution and discharge to solid-state adsorber, 4B+2C	Use common materials Elemental arsenic can be present in cylinder and lines. Disposal products contain arsenic compounds (toxic) $\text{AsH}_3 + 4 \text{H}_2\text{O} \rightarrow \text{AsO}_4^{3-} + 11 \text{H}^+ + 8\text{e}^-$ (Method 2B) Oxidants that can be used include permanganate or hypochlorite Adsorption on charcoal or on CuSO_4 -treated silicagel $3 \text{CuSO}_4 + 2 \text{AsH}_3 \rightarrow \text{Cu}_3\text{As}_2 + 3 \text{H}_2\text{SO}_4$ (Method 2C)
Boron tribromide BBr_3 T2 C1	Toxic, $\text{LC}_{50/1\text{h}} = 380$ vpm Liquid, bp ca. 92°C , vp ca. 0,06 bar abs Poor warning properties Corrosive when moist	Recycling, 1 Discharge to scrubber, 2B	Use common materials $\text{BBr}_3 + 3 \text{OH}^- \rightarrow \text{BO}_3^{3-} + 3 \text{HBr}$ (Methods 2 B)
Boron trichloride BCl_3 T2 C1	Toxic, $\text{LC}_{50/1\text{h}} = 2541$ vpm Very corrosive when moist, hydrochloric acid formed Liquefied gas, bp ca 12°C , vp ca 0,3 bar Vapour 4 x heavier than air Pungent odour, white fumes in air	Recycling, 1 Discharge to scrubber, 2A or 2B	Use copper, Monel, Hastelloy, heavy gauge mild steel, PVC or PTFE Ensure that blockage by corrosion products does not give false indication of empty cylinder or system $4 \text{BCl}_3 + 14 \text{NaOH} \rightarrow 12 \text{NaCl} + \text{Na}_2\text{B}_4\text{O}_7 + 7 \text{H}_2\text{O}$ (Methods 2A and 2B)

1 Gas EC classification	2 Key characteristics	3 Disposal method	4 Key operational/safety consideration
Boron trifluoride BF ₃ T2 C1	Toxic, LC _{50/1h} = 387 vpm Very corrosive when moist, hydrofluoric acid formed Gas 2,5 x heavier than air Critical temperature -12°C Pungent odour, white fumes in air	Recycling, 1 Discharge to scrubber, 2B	Avoid PVC Use copper, heavy gauge mild steel, (aluminium), PTFE, polyethylene Beware of danger of hydrofluoric acid formed (risk of severe chemical burns) Ensure that blockage by corrosion products does not give false indication of empty cylinder or system Unwanted residual gases shall be securely contained and safely transported to a facility properly equipped and staffed for disposal. Extra care , seek specialist advice! $16 \text{ BF}_3 + 14 \text{ NaOH} \rightarrow$ $12 \text{ NaBF}_4 + \text{Na}_2\text{B}_4\text{O}_7 + 7 \text{ H}_2\text{O}$ (Method 2B)
Bromine trifluoride BrF ₃ T1 O C	Very toxic, LC _{50/1h} = 180 vpm Extremely powerful oxidant Corrosive Liquid, bp ca 126°C Pungent odour	Recycling, 1 Dilution and discharge to scrubber, 4B+2B	Unwanted residual gases shall be securely contained and safely transported to a facility properly equipped and staffed for disposal. Extra care , seek specialist advice! In the event of eye or skin contact, immediately wash with copious amounts of water Avoid grease and all other combustible contaminants Use Monel nickel or heavy gauge mild steel and PTFE Preclean and passivate all materials in use Reacts violently with water Initially introduce only small quantities until one is convinced system is passivated
Bromomethane CH ₃ Br T2 N	Toxic, LC _{50/1h} = 850 vpm Systemic poison with persistent and sometimes delayed effects Flammable, 8,6-14,5 % in air Poor warning properties Liquefied gas, bp ca. +4°C, vp ca. 0,9 bar Vapour 3 x heavier than air	Recycling, 1 Incineration, 3C followed by Discharge to scrubber, 2B	Avoid aluminium, magnesium and zinc Avoid plastics, rubber etc. with liquid Use other common metals and PTFE Toxic products produced by burning $\text{CH}_3\text{Br} + 1,5 \text{ O}_2 \rightarrow \text{CO}_2 + \text{H}_2\text{O} + \text{HBr}$ (Method 3C) $\text{HBr} + \text{OH}^- \rightarrow \text{H}_2\text{O} + \text{Br}^-$ (Method 2B)

1 Gas EC classification	2 Key characteristics	3 Disposal method	4 Key operational/safety consideration
1,2-Butadiene C ₄ H ₆ F1	Flammable, 1,4 -11,5 % in air Liquefied gas bp ca. +11°C, vp ca. 0,5 bar Moderate odour warning	Recycling, 1 Direct combustion, 3A Combustion/incineration, 3B	Avoid plastics, rubber etc. with liquid Use common materials for vapour C ₄ H ₆ + 5,5 O ₂ → 4 CO ₂ + 3H ₂ O (Methods 3A and 3B)
1,3-Butadiene C ₄ H ₆ F1	Carcinogenic Flammable, 1,4 -11,5 % in air Subject to self polymerization Liquefied gas bp ca. -4°C, vp ca. 1,5 bar Moderate odour warning Vapour 2 x heavier than air	Recycling, 1 Direct combustion, 3A Combustion/incineration, 3B	Avoid plastics, rubber etc. with liquid Use common materials for vapour Guard against polymer blockage Check that content is stable: i.e. no temperature rise of cylinder C ₄ H ₆ + 5,5 O ₂ → 4 CO ₂ + 3H ₂ O (Methods 3A and 3B)
n-Butane C ₄ H ₁₀ F1	Flammable, 1,4 -8,5 % in air Poor warning properties (unless stenched) Liquefied gas bp ca. -1°C, vp ca 1,0 bar Vapour 2 x heavier than air	Recycling, 1 Direct combustion, 3A Combustion/incineration, 3B	Avoid plastics, rubber Use common materials for vapour C ₄ H ₁₀ + 6,5 O ₂ → 4 CO ₂ + 5 H ₂ O (Methods 3A and 3B)
iso-Butane C ₄ H ₁₀ F1	Flammable, 1,5 -8,4 % in air Poor warning properties Liquefied gas, bp ca. -12°C, vp ca. 2 bar Vapour 2 x heavier than air	Recycling, 1 Direct combustion, 3A Combustion/incineration, 3B	Avoid plastics, rubber etc with liquid Use common materials for vapour C ₄ H ₁₀ + 6,5 O ₂ → 4 CO ₂ +5 H ₂ O (Methods 3A and 3B)

1 Gas EC classification	2 Key characteristics	3 Disposal method	4 Key operational/safety consideration
1-Butene C ₄ H ₈ F1	Flammable, 1,5 -9,3 % in air Poor warning properties (unless stenched) Liquefied gas bp ca. -6°C, vp ca. 1,6 bar Vapour 2 x times heavier than air	Recycling, 1 Direct combustion, 3A Combustion/incineration, 3B	Avoid plastics, rubber, etc. with liquid Use common materials for vapour C ₄ H ₈ + 6 O ₂ → 4 CO ₂ + 4 H ₂ O (Methods 3A and 3B)
cis-2-Butene C ₄ H ₈ F1	Flammable, 1,5 -9,4 % in air Poor warning properties (unless stenched) Liquefied gas bp ca. +4°C, vp ca. 0,9 bar Vapour 1,5 x heavier than air	Recycling, 1 Direct combustion, 3A Combustion/incineration, 3B	Avoid plastic, rubber etc with liquid Use common materials for vapour C ₄ H ₈ + 6 O ₂ → 4 CO ₂ + 4 H ₂ O (Methods 3A and 3B)
Trans-2-Butene C ₄ H ₈ F1	Flammable, 1,5 -9,7 % in air Poor warning properties (unless stenched) Liquefied gas, bp ca. +1°C, vp ca. 1 bar Vapour 2 x heavier than air	Recycling, 1 Direct combustion, 3A Combustion/incineration, 3B	Avoid plastics, rubber, etc. with liquid Use common materials for vapour C ₄ H ₈ + 6 O ₂ → 4 CO ₂ + 4 H ₂ O (Methods 3A and 3B)
iso-Butene C ₄ H ₈ F1	Flammable, 1,5 -9,7 % in air Poor warning properties (unless stenched) Liquefied gas, bp ca. -7°C, vp ca. 1,6 bar Vapour 2 x heavier than air	Recycling, 1 Direct combustion, 3A Combustion/incineration, 3B	Avoid plastics, rubber, etc. with liquid Use common materials for vapour C ₄ H ₈ + 6 O ₂ → 4 CO ₂ + 4 H ₂ O (Methods 3A and 3B)

1 Gas EC classification	2 Key characteristics	3 Disposal method	4 Key operational/safety consideration
Carbon dioxide CO ₂ A	Asphyxiant Poor warning properties Liquefied gas, sublimation point ca. -78°C, vp ca 55 bar Vapour 1,5 x heavier than air	Recycling, 1 Direct discharge 4A, 4B or controlled release unless restricted by local regulation	Cryogenic solid can cause cold burns Use common materials
Carbon monoxide CO F1 T3	Toxic, LC _{50/1h} = 3760 vpm Flammable, 10,9 -74 % in air No warning properties Gas similar density as air	Recycling, 1 Direct combustion, 3A Incineration, 3C	Use common materials Beware of possibility of toxic carbonyls remaining in the cylinder after emptying CO + 0,5 O ₂ → CO ₂ (Methods 3A and 3C)
Carbonyl fluoride COF ₂ T2 C1	Toxic, LC _{50/1h} = 360 vpm Corrosive when moist Poor odour warning (at toxic level) Liquefied gas, bp ca -85°C, vp ca. 55 bar Critical temperature 24°C Vapour 2,5 heavier than air	Recycling, 1 Discharge to scrubber, 2B Discharge to solid-state absorber, 2C Dilution and discharge to solid-state adsorber, 4B+2C	Beware of formation of hydrofluoric acid Risk for severe chemical burns Ensure that blockage by corrosion products does not give false indication of empty cylinder or system Avoid plastics, rubber, etc. with liquid Use copper, Monel, nickel, heavy gauge mild steel and PTFE COF ₂ + 4 OH ⁻ → CO ₃ ²⁻ + 2 F ⁻ + 2 H ₂ O (Method 2B) Adsorption on soda lime (Method 2C)
Carbonyl sulphide COS F1 T3	Toxic, LC _{50/1h} = 1700 vpm Corrosive when moist Poor odour warning (at toxic level) Liquefied gas, bp ca. -50°C, vp ca. 10 bar Vapour 2 x heavier than air	Recycling, 1 Incineration, 3C followed by Discharge to scrubber, 2A or 2B Discharge to solid-state adsorber, 2C Dilution and discharge to solid-state adsorber, 4B+2C	Ensure that blockage by corrosion products does not give false indication of empty cylinder or system Avoid plastics, rubber, etc. with liquid Use aluminium, stainless steel, PTFE COS + 1,5 O ₂ → CO ₂ + SO ₂ (Method 3C) SO ₂ + 2 OH ⁻ → SO ₃ + H ₂ O (Methods 2A and 2B) Adsorption on soda lime (Method 2C)

1 Gas EC classification	2 Key characteristics	3 Disposal method	4 Key operational/safety consideration
Chlorine Cl ₂ O T2 C2 N1	Toxic, LC _{50/1 h} = 293 vpm Powerful oxidizing agent Very corrosive when moist Liquefied gas bp ca. -34°C, vp ca 6 bar Vapour 2,5 x heavier than air Good odour warning, irritating, suffocating	Recycling, 1 Discharge to scrubber, 2B Dilution and discharge to solid-state adsorber, 4B+2C	Ensure that blockage by corrosion products does not give false indication of empty cylinder or system Avoid grease and other combustible contaminants Use heavy gauge mild steel, precleaned and passivated $\text{Cl}_2 + 2 \text{OH}^- \rightarrow \text{Cl}^- + \text{ClO}^- + \text{H}_2\text{O}$ $\text{S}_2\text{O}_3^{2-} + 4 \text{ClO}^- + 2 \text{OH}^- \rightarrow 2 \text{SO}_4^{2-} + 4 \text{Cl}^- + \text{H}_2\text{O}$ (Methods 2B) Adsorption on soda lime (Method 2C)
Chlorine pentafluoride ClF ₅ O T1 C1	Very toxic, LC _{50/1 h} = 122 vpm Powerful oxidizing agent Extremely reactive and corrosive (hypergolic) Liquefied gas, bp ca. -13°C, vp ca. 1,5 bar	Recycling, 1 Dilution with inert gas and discharge to scrubber, 2B	The product shall not be disposed in its liquid phase due to its high reactivity. The gas phase should be diluted because of its exothermic reaction. Unwanted residual gases shall be securely contained and safely transported to a facility properly equipped and staffed for disposal. Extra care , seek specialist advice! If contacted with skin, wash with copious amounts of water Avoid grease and all other combustible contaminants Use copper, Monel, heavy gauge mild steel precleaned and passivated, PTFE) Reacts violently with water Ensure that blockage by corrosion products does not give false indication of empty cylinder or system Introduce initially only small quantities until one is convinced system is passivated $4\text{ClF}_5 + 24\text{OH}^- = 3\text{ClO}_4^- + \text{Cl}^- + 20\text{F}^- + 12\text{H}_2\text{O}$

1 Gas EC classification	2 Key characteristics	3 Disposal method	4 Key operational/safety consideration
Chlorine trifluoride ClF ₃ O T2 C2	Toxic, LC _{50/1 h} = 299 vpm Very powerful oxidizing agent Extremely reactive and corrosive (hypergolic) Liquefied gas, bp ca. 12°C, vp ca. 0,5 bar Vapour 3 x heavier than air Good odour warning	Recycling, 1 Dilution with inert gas and discharge to scrubber, 2B	The product shall not be disposed in its liquid phase due to its high reactivity. The gas phase should be diluted because of its exothermic reaction. Unwanted residual gases shall be securely contained and safely transported to a facility properly equipped and staffed for disposal. Extra care , seek specialist advice! If contacted with skin, wash with copious amounts of water Avoid grease and all other combustible contaminants Use copper, Monel, heavy gauge mild steel precleaned and passivated, PTFE) Reacts violently with water Ensure that blockage by corrosion products does not give false indication of empty cylinder or system Introduce initially only small quantities until one is convinced system is passivated $3\text{ClF}_3 + 12\text{OH}^- = 2\text{ClO}_3^- + \text{Cl}^- + 9\text{F}^- + 6\text{H}_2\text{O}$
Chloroethane C ₂ H ₅ Cl F1	Flammable, 3,6 -15,4 % in air Liquefied gas, bp ca. 12°C, vp ca. 0,4 bar Vapour 2 x heavier than air Moderate odour warning (ethereal)	Recycling, 1 Incineration, 3C followed by Discharge to scrubber, 2B	Avoid aluminium, magnesium and zinc Avoid plastics, rubber etc with liquid Use other common materials $\text{C}_2\text{H}_5\text{Cl} + 3 \text{O}_2 \rightarrow 2 \text{CO}_2 + \text{HCl} + 2 \text{H}_2\text{O}$ (Method 3C) $\text{HCl} + \text{OH}^- \rightarrow \text{Cl}^- + \text{H}_2\text{O}$ (Method 2B)
Chloromethane CH ₃ Cl F1 T4	Harmful, LC _{50/1 h} = 8300 vpm Flammable, 7,6 -17,2 % in air No warning properties Liquefied gas, bp ca. -24°C, vp ca. 4 bar Vapour 2 x heavier than air	Recycling, 1 Incineration, 3C followed by Discharge to scrubber, 2B	Avoid aluminium Avoid plastics, rubber etc with liquid Use other common materials, PTFE $\text{CH}_3\text{Cl} + 1,5 \text{O}_2 \rightarrow \text{CO}_2 + \text{HCl} + \text{H}_2\text{O}$ (Method 3C) $\text{HCl} + \text{OH}^- \rightarrow \text{Cl}^- + \text{H}_2\text{O}$ (Method 2B)

1 Gas EC classification	2 Key characteristics	3 Disposal method	4 Key operational/safety consideration
Cyanogen C_2N_2 F1 T3 N1	Toxic, $LC_{50/1h} = 350$ vpm Fast acting irreversible systemic poison Flammable, 3,9 -32 % in air No warning properties (almond like odour) Liquefied gas, bp ca. $-21^\circ C$, vp ca. 4 bar Vapour 2 x heavier than air	Recycling, 1 Incineration, 3C followed by Discharge to scrubber, 2B	Immediate expert medical attention should be available in case of poisoning Use stainless steel, Monel, heavy gauge mild steel and PTFE $C_2N_2 + 2 O_2 \rightarrow 2 CO_2 + N_2$ (Method 3C) Burning with hot, efficient flame. Control combustion conditions to minimize formation of nitrogen oxides.
Cyanogen chloride CNCl T1 C1	Very toxic, $LC_{50/1h} = 80$ vpm Fast acting irreversible systemic poison Liquefied gas, bp ca. $+13^\circ C$, vp ca. 0,5 bar Vapour 2 x heavier than air	Recycling, 1 Discharge to scrubber, 2B	Immediate expert medical attention should be available in case of poisoning Use stainless steel, Monel, heavy gauge mild steel and PTFE $CNCl + 2 OH^- \rightarrow OCN^- + Cl^- + H_2O$ (pH > 11) $2 OCN^- + 3 OCl^- + 2 OH^- \rightarrow N_2 + 2 CO_3^{2-} + H_2O$ (Method 2B)
Cyclobutane C_4H_8 F1	Flammable, 1,8 - 11 % in air Poor warning properties Liquefied gas bp ca. $+13^\circ C$, vp ca. 0,3 bar Vapour 2 x heavier than air	Recycling, 1 Direct combustion, 3A Combustion/incineration, 3B	Avoid plastics, rubber, etc with liquid Use common materials with vapour $C_4H_8 + 6O_2 = 4CO_2 + 4H_2O$ (Methods 3A and 3B)
Cyclopropane C_3H_6 F1	Flammable, 2,4-10,4 % in air Poor warning properties (unless stenched) Liquefied gas, bp ca $-33^\circ C$, vp ca. 5 bar Vapour 1,5 x heavier than air	Recycling, 1 Direct combustion, 3A Combustion/incineration, 3B	Avoid plastics, rubber, etc with liquid Use common materials with vapour $C_3H_6 + 4,5 O_2 \rightarrow 3 CO_2 + 3 H_2O$ (Methods 3A and 3B)

1 Gas EC classification	2 Key characteristics	3 Disposal method	4 Key operational/safety consideration
Deuterium D ₂ F1	Flammable, 6,7 -75 % in air No warning properties Gas 7 x lighter than air	Recycling, 1 Controlled dilution, 4C Direct combustion, 3A Incineration, 3C	Use common materials D ₂ + 0,5 O ₂ → D ₂ O (Methods 3A and 3C)
Diborane B ₂ H ₆ T1 F1	Very toxic, LC _{50/1 h} = 80 vpm Flammable, 0,9-98 % in air Subject to exothermic decomposition Normally only a minor component in mixtures Gas density similar to air Moderate odour warning (liquefied gas, bp ca. - 92°C, vp ca 38 bar, critical temperature 16°C)	Direct Discharge to scrubber, 2B Incineration, 3C followed by Discharge to scrubber, 2B	Use common materials Beware possibility of higher boranes (spontaneously flammable) remaining in cylinder. Note: Guard against polymer blockage is recommended. 2 B ₂ H ₆ + 2 OH ⁻ + 5 H ₂ O → B ₄ O ₇ ²⁻ + 12 H ₂ (Method 2B) B ₂ H ₆ + 3 O ₂ → B ₂ O ₃ + 3 H ₂ O (Method 3C) B ₂ O ₃ + 3 H ₂ O → 2 H ₃ BO ₃ (Method 2B) Voluminous cloud of B ₂ O ₃ can be produced Beware for blockage of pipeworks/nozzles by B ₂ O ₃
Dichlorosilane SiH ₂ Cl ₂ F1 T2 C1	Toxic, LC _{50/1 h} = 314 vpm Flammable, 2,5 -98,8 % in air Spontaneous ignition/self decomposition is possible around 100°C or by shock Liquefied gas, bp ca. +8°C, vp ca 0,6 bar Vapour 4 x heavier than air Moderate odour warning (suffocating)	Recycling, 1 Direct Discharge to scrubber, 2B Incineration, 3C followed by Discharge to scrubber, 2B	Ensure that blockage by corrosion/combustion products does not give false indication of empty cylinder or system. Use nickel, nickel steels, stainless steels, heavy gauge mild steel and PTFE. Discharge as slowly as possible to minimize local heating and risk of ignition. Forms hydrochloric acid and hydrogen in presence of water. SiH ₂ Cl ₂ + 2 NaOH + H ₂ O → Na ₂ SiO ₃ + 2 HCl + 2 H ₂ (Methods 2B) SiH ₂ Cl ₂ + O ₂ → SiO ₂ + 2 HCl (Method 3C) HCl + NaOH → NaCl + H ₂ O (Method 2B)

1 Gas EC classification	2 Key characteristics	3 Disposal method	4 Key operational/safety consideration
Dimethylamine C_2H_7N F1 T4	Harmful, $LC_{50/1h} = 11000$ vpm Flammable, 2,8-14,4 % in air Corrosive when moist Liquefied gas, bp ca. $+7^{\circ}C$, vp ca 0,6 bar Vapour 1,5 heavier than air Good odour warning (fishlike, ammoniacal)	Recycling, 1 Incineration, 3C followed by discharge to scrubber, 2A or 2B Discharge to scrubber, 2A or 2B Discharge to solid state absorber, 2C	Avoid copper, nickel, mercury, tin, zinc Avoid plastics, rubber, etc with liquid Use steel and PTFE $2 C_2H_7N + 7,5 O_2 \rightarrow 4 CO_2 + 7 H_2O + N_2$ Control combustion conditions to minimize NO_2 production (Method 3C) $2 (CH_3)_2NH + H_2SO_4 \rightarrow 2 (CH_3)_2NH_2^+ + SO_4^{2-}$ (Methods 2A and 2B) Adsorption on activated charcoal (Method 2C)
Dimethyl ether C_2H_6O F1	Flammable, 2,7 -27 % in air Liquefied gas, bp ca. $-25^{\circ}C$, vp ca. 4 bar Vapour 1,5 x heavier than air Moderate odour warning (ethereal)	Recycling, 1 Direct combustion, 3A Combustion/incineration, 3B	Avoid plastics, rubber etc. with liquid Use common materials for vapour $C_2H_6O + 3 O_2 \rightarrow 2 CO_2 + 3 H_2O$ (Methods 3A and 3B)
2,2-Dimethylpropane C_5H_{12} F1	Flammable, 1,3 -7,5 % in air Poor warning properties Liquefied gas, bp ca. $+10^{\circ}C$, vp ca. 0,5 bar Vapour 2,5 x heavier than air	Recycling, 1 Direct combustion, 3A Combustion/incineration, 3B	Avoid plastics, rubber etc. with liquid Use common materials for vapour $C_5H_{12} + 8 O_2 \rightarrow 5 CO_2 + 6 H_2O$ (Methods 3A and 3B)
Dimethylsilane $(CH_3)_2SiH_2$ F1	Flammable, 1,2 - 74 % in air Poor warning properties Liquefied gas, bp ca. $-20^{\circ}C$, vp ca. 3 bar Vapour 2,1 x heavier than air.	Combustion/incineration, 3C	Ensure blockage by combustion products does not give false indication of empty cylinder or system Use common materials $(CH_3)_2SiH_2 + 5 O_2 \rightarrow 2 CO_2 + SiO_2 + 4 H_2O$ (Method 3C)

1 Gas EC classification	2 Key characteristics	3 Disposal method	4 Key operational/safety consideration
Disilane Si_2H_6 F1	Spontaneously flammable in air (pyrophoric) Liquefied gas, bp ca. -14°C , vp ca. 2 bar Vapour 2,2 x heavier than air	Combustion/incineration, 3C	Ensure blockage by combustion products does not give false indication of empty cylinder or system Use common materials $\text{Si}_2\text{H}_6 + 3,5 \text{O}_2 \rightarrow 2 \text{SiO}_2 + 3 \text{H}_2\text{O}$ (Method 3C)
Ethane C_2H_6 F1	Flammable, 2,4 -12,4 % in air Poor warning properties Liquefied gas, bp ca. -88°C , vp ca. 37 bar Critical temperature $+32^\circ\text{C}$ Vapour density similar to air	Recycling, 1 Direct discharge, 4B Controlled release, 4C Controlled dilution 4D Direct combustion, 3A Combustion/incineration, 3B	Avoid plastics, rubber etc. with liquid Use common materials for vapour $\text{C}_2\text{H}_6 + 3,5 \text{O}_2 \rightarrow 2 \text{CO}_2 + 3 \text{H}_2\text{O}$ (Methods 3A and 3B)
Ethylnacetylene C_4H_6 F1	Flammable, 1,3-33% in air Poor warning properties Liquefied gas, bp ca. $+8^\circ\text{C}$, vp ca. 0,6 bar Vapour 2 x heavier than air	Recycling, 1 Direct combustion, 3A Combustion/incineration, 3B	Avoid air suckback Avoid copper and silver Avoid plastics, rubber etc. with liquid Use steel, brass with less than 70 % copper $\text{C}_4\text{H}_6 + 5,5 \text{O}_2 \rightarrow 4 \text{CO}_2 + 3 \text{H}_2\text{O}$ (Methods 3A and 3B)
Ethylamine $\text{C}_2\text{H}_7\text{N}$ F1 T4	Flammable, 3,5-13,9% in air Corrosive when moist Liquefied gas, bp ca. $+17^\circ\text{C}$, vp ca. 0,2 bar Vapour 1,5 x heavier than air Good odour warning (fishlike, ammoniacal)	Recycling, 1 incineration, 3C followed by discharge to scrubber, 2A or 2B Discharge to scrubber, 2A or 2B Discharge to solid state absorber, 2C	Avoid copper, nickel, tin, zinc Avoid plastics, rubber etc with liquid Use steel and PTFE $2 \text{C}_2\text{H}_7\text{N} + 7,5 \text{O}_2 \rightarrow 4 \text{CO}_2 + \text{N}_2 + 7 \text{H}_2\text{O}$ Control combustion conditions to minimize NO_2 production (Method 3C) $2 \text{C}_2\text{H}_7\text{N} + \text{H}_2\text{SO}_4 \rightarrow 2 \text{C}_2\text{H}_5\text{NH}_3^+ + \text{SO}_4^{2-}$ (Methods 2A and 2B) Adsorption on activated charcoal (Method 3C)

1 Gas EC classification	2 Key characteristics	3 Disposal method	4 Key operational/safety consideration
Ethyl methyl ether C ₃ H ₈ O F1	Flammable, 2,0 - 18 % in air Liquefied gas, bp ca. +11°C, vp ca. 0,6 bar Vapour 2 x heavier than air Moderate warning properties (ethereal)	Recycling, 1 Direct combustion, 3A Combustion/incineration, 3B	Avoid plastics, rubber etc. with liquid Use common materials for vapour $C_3H_8O + 4,5 O_2 \rightarrow 3 CO_2 + 4 H_2O$ (Methods 3A and 3B)
Ethylene C ₂ H ₄ F1	Flammable, 2,4 -36 % in air Critical temperature +9,9°C Poor warning properties Gas density similar to air	Recycling, 1 Direct combustion, 3A	Use common materials If temperature falls below 10°C ensure liquid ethylene is not left in the cylinder or system $C_2H_4 + 3 O_2 \rightarrow 2 CO_2 + 2 H_2O$ (Method 3A)
Ethylene oxide C ₂ H ₄ O F1 T 3 C2	Toxic, LC _{50/1 h} = 2900 vpm Flammable, 2,6 -100 % in air Vapour can explode by spark, detonation or heating above 440°C Subject to exothermic self decomposition and self polymerization Poor warning properties Liquefied gas, bp ca 11 °C, vp ca. 0,4 bar Vapour 1,5 x heavier than air	Recycling, 1 Discharge into counter-flow scrubber 2B Combustion/incineration 3B Incineration, 3C	Avoid suckback of water, acid or alkali or other catalysts Liquid and aqueous solutions are corrosive to skin and eyes Liquid causes cold burns Avoid magnesium and silver Avoid plastics, rubber etc with liquid Use precleaned and dried steel and PTFE Ensure polymer blockage or skinning does not give false indication of emptied cylinder or system Absorption of ethylene oxide in a counter-flow scrubber and its subsequent hydration to ethylene glycol. Reaction rate is a function of temperature in the presence of a catalyst, typically sulphuric acid.(Method 2B) $C_2H_4O + 2,5 O_2 \rightarrow 2 CO_2 + 2 H_2O$ (Method 3B) Only diluted gas with about 10 % ethylene oxide (Method 3C) Containers are commonly pressurized to 5-7 bars with nitrogen

1 Gas EC classification	2 Key characteristics	3 Disposal method	4 Key operational/safety consideration
Fluorine F ₂ O T1 C1	Toxic, LC _{50/1 h} = 185 vpm Powerful oxidizing agent Very corrosive when moist Liquefied gas bp ca. -188°C, Vapour 1,3 x heavier than air Good odour warning, irritating, suffocating	Recycling, 1 Dilution and discharge to solid-state adsorber, 4B+2C	Control the heat reaction by dilution and/or by refrigerating the solid state adsorber Ensure that blockage by corrosion products does not give false indication of empty cylinder or system Avoid grease and other combustible contaminants Use heavy gauge mild steel, precleaned and passivated Adsorption on Aluminium Oxide 6F ₂ + 2Al ₂ O ₃ -> 4AlF ₃ + 3O ₂ (Method 2C)
Fluoroethane C ₂ H ₅ F F1	Flammable, 3,8 -15,4 % in air Poor warning properties Corrosive when moist Liquefied gas, bp ca. -35°C, vp ca 7 bar Vapour 1,5 x heavier than air	Recycling, 1 High temperature Incineration, 3C, followed by scrubbing, 2B	Avoid plastics, rubber etc. with liquid Use common materials for vapour High temperature decomposition products are toxic
Fluoromethane CH ₃ F F1	Flammable, 5,6 upper limit un-established No warning properties Liquefied gas, bp ca.-78°C, vp ca. 33 bar Vapour density similar to air	Recycling, 1 High temperature Incineration, 3C, followed by scrubbing, 2B	Avoid plastics, rubber etc. with liquid Use common materials for vapour High temperature decomposition products are toxic
Germane GeH ₄ F1 T1	Very toxic, LC _{50/1 h} = 620 vpm Spontaneously flammable in air (pyrophoric) Liquefied gas, bp ca. -88°C, vp ca. 45 bar Gas 3 x heavier than air Good warning properties (flames and smoke)	Recycling, 1 Incineration, 3C	Ensure blockage by combustion products does not give false indication of empty cylinder or system Use common materials High temperature decomposition products are toxic GeH ₄ + 2 O ₂ → GeO ₂ + 2 H ₂ O (Method 3C)

1 Gas EC classification	2 Key characteristics	3 Disposal method	4 Key operational/safety consideration
Halocarbon R11 CCl ₃ F A	Asphyxiant No warning properties High temperature decomposition products are toxic Liquid, bp ca. 24°C, vp ca. 0,9 bar abs Vapour 4,5 x heavier than air	Recycling, 1 High temperature Incineration, 3C, followed by scrubbing, 2B	Avoid plastics, rubber etc. with liquid Use common materials for vapour
Halocarbon R12 CCl ₂ F ₂ A	Asphyxiant No warning properties High temperature decomposition products are toxic Liquefied gas, bp ca. -30°C, vp ca. 5 bar Vapour 4 x heavier than air	Recycling, 1 High temperature Incineration, 3C, followed by scrubbing, 2B	Avoid plastics, rubber etc. with liquid Use common materials for vapour
Halocarbon R12B1 CBrClF ₂ A	Asphyxiant No warning properties High temperature decomposition products are toxic Liquefied gas, bp ca. -4°C, vp ca. 1,4 bar Vapour 6 x heavier than air	Recycling, 1 High temperature Incineration, 3C, followed by scrubbing, 2B	Avoid plastics, rubber etc. with liquid Use common materials for vapour
Halocarbon R12B2 CBr ₂ F ₂ A	Asphyxiant, 100 vpm TLV No warning properties High temperature decomposition products are toxic Liquid, bp ca. +25°C, vp ca. 1 bar absolute Vapour 7 x heavier than air	Recycling, 1 High temperature Incineration, 3C, followed by scrubbing, 2B	Avoid plastics, rubber etc. with liquid Use common materials for vapour

1 Gas EC classification	2 Key characteristics	3 Disposal method	4 Key operational/safety consideration
Halocarbon R13 CClF ₃ A	Asphyxiant No warning properties High temperature decomposition products are toxic Liquefied gas, bp ca. -81°C, vp ca. 31 bar Vapour 3,5 x heavier than air	Recycling, 1 High temperature Incineration, 3C, followed by scrubbing, 2B	Avoid plastics, rubber etc. with liquid Use common materials for vapour
Halocarbon R13B1 CF ₃ Br A	Asphyxiant No warning properties High temperature decomposition products are toxic Liquefied gas, bp ca. -58°C, vp ca. 14 bar Vapour 3,5 x heavier than air	Recycling, 1 High temperature Incineration, 3C, followed by scrubbing, 2B	Avoid plastics, rubber etc. with liquid Use common materials for vapour
Halocarbon R14 CF ₄ A	Asphyxiant No warning properties High temperature decomposition products are toxic Vapour 3 x heavier than air	Recycling, 1 High temperature Incineration, 3C, followed by scrubbing, 2B	Use common materials for vapour
Halocarbon R21 CHCl ₂ F A	Asphyxiant No warning properties High temperature decomposition products are toxic Liquefied gas, bp ca. +9°C, vp ca. 0,5 bar Vapour 3,5 x heavier than air	Recycling, 1 High temperature Incineration, 3C, followed by scrubbing, 2B	Avoid plastics, rubber etc. with liquid Use common materials for vapour

1 Gas EC classification	2 Key characteristics	3 Disposal method	4 Key operational/safety consideration
Halocarbon R22 CHClF ₂ A	Asphyxiant No warning properties High temperature decomposition products are toxic Liquefied gas, bp ca. -41°C, vp ca. 8 bar Vapour 3 x heavier than air	Recycling, 1 High temperature Incineration, 3C, followed by scrubbing, 2B	Avoid plastics, rubber etc. with liquid Use common materials for vapour
Halocarbon R23 CHF ₃ A	Asphyxiant No warning properties High temperature decomposition products are toxic Liquefied gas, bp ca. -82°C, vp ca. 44 bar Vapour 2,5 x heavier than air	Recycling, 1 High temperature Incineration, 3C, followed by scrubbing, 2B	Avoid plastics, rubber etc. with liquid Use common materials for vapour
Halocarbon R113 C ₂ Cl ₃ F ₃ A	High temperature decomposition products are toxic Liquid, bp ca. +48°C, vp ca. 0,4 bar absolute	Recycling, 1 High temperature Incineration, 3C, followed by scrubbing, 2B	Avoid plastics, rubber etc. with liquid Use common materials for vapour
Halocarbon R124a C ₂ HF ₄ Cl A	Asphyxiant Poor warning properties High temperature decomposition products are toxic Liquefied gas, bp ca. -11°C, vp ca. 2 bar Vapour 5 x heavier than air	Recycling, 1 High temperature Incineration, 3C followed by scrubbing, 2B	Avoid plastics, rubber etc. with liquid Use common materials for vapour

1 Gas EC classification	2 Key characteristics	3 Disposal method	4 Key operational/safety consideration
Halocarbon R133a <chem>C2H2F3Cl</chem> A	Asphyxiant No warning properties High temperature decomposition products are toxic Liquefied gas, bp ca. +7°C, vp ca. 0,8 bar Vapour 5 x heavier than air	Recycling, 1 High temperature Incineration, 3C, followed by scrubbing, 2B	Avoid plastics, rubber etc. with liquid Use common materials for vapour
Halocarbon R142b <chem>C2H3ClF2</chem> F1	Flammable, 9-14,8 % in air No warning properties High temperature decomposition products are toxic Liquefied gas, bp ca. -10°C, vp ca. 2 bar Vapour 3,5 x heavier than air	Recycling, 1 High temperature Incineration, 3C, followed by scrubbing, 2B	Avoid plastics, rubber etc. with liquid Use common materials for vapour
Halocarbon R143a <chem>C2H3F3</chem> F1	Flammable 7,0 - 19 % in air Poor warning properties High temperature decomposition products are toxic Liquefied gas, bp ca. -48 °C, vp ca. 10 bar Vapour 2,9 x heavier than air	Recycling, 1 High temperature Incineration, 3C, followed by scrubbing, 2B	Avoid plastics, rubber etc. with liquid Use common materials for vapour
Halocarbon R152a <chem>C2H4F2</chem> F1	Flammable, 4-18 % in air No warning properties High temperature decomposition products are toxic Liquefied gas, bp ca. -25°C, vp ca. 4 bar Vapour 2,5 x heavier than air	Recycling, 1 High temperature Incineration, 3C, followed by scrubbing, 2B	Avoid plastics, rubber etc. with liquid Use common materials for vapour

1 Gas EC classification	2 Key characteristics	3 Disposal method	4 Key operational/safety consideration
Halocarbon R218 C_3F_8 A	Asphyxiant Poor warning properties High temperature decomposition products are toxic Liquefied gas, bp ca. $-37^{\circ}C$, vp ca. 7 bar Vapour 7 x heavier than air	Recycling, 1 High temperature Incineration, 3C, followed by scrubbing, 2B	Avoid plastics, rubber etc. with liquid Use common materials for vapour
Halocarbon R227 C_3HF_7 A	Asphyxiant Poor warning properties High temperature decomposition products are toxic Liquefied gas, bp ca. $-17^{\circ}C$, vp ca. 3 bar Vapour 6 x heavier than air	Recycling, 1 High temperature Incineration, 3C, followed by scrubbing, 2B	Avoid plastics, rubber etc. with liquid Use common materials for vapour
Halocarbon RC318 C_4F_8 A	Asphyxiant No warning properties High temperature decomposition products are toxic Liquefied gas, bp ca. $-6^{\circ}C$, vp ca. 1,5 bar Vapour 7 x heavier than air	Recycling, 1 High temperature Incineration, 3C, followed by scrubbing, 2B	Avoid plastics, rubber etc. with liquid Use common materials for vapour
Halocarbon R1113 C_2ClF_3 F1	Flammable, 4,6 -38,7 % in air No warning properties High temperature decomposition products are toxic Liquefied gas, bp ca. $-28^{\circ}C$, vp ca. 4 bar Vapour 4 x heavier than air	Recycling, 1 High temperature Incineration, 3C, followed by scrubbing, 2B	Avoid plastics, rubber etc. with liquid Use common materials for vapour

1 Gas EC classification	2 Key characteristics	3 Disposal method	4 Key operational/safety consideration
Halocarbon R113B1 C_2BrF_3 F1	Flammable, 8,4-38,7 % in air Poor warning properties Liquefied gas, bp ca. -2°C, vp ca. 1,5 bar Vapour 5 x heavier than air	Recycling, 1 High temperature Incineration, 3C, followed by scrubbing, 2B	Avoid alloys with > 2 % magnesium; aluminium and plastics Use other common metals and PTFE
Halocarbon R1114 C_2F_4 F1	Flammable, 10,5 -60 % in air High temperature decomposition products are toxic Subject to violent self polymerization Liquefied gas, bp ca. -76°C, vp ca. 25 bar Poor warning properties Gas 3 x heavier than air	Recycling, 1 High temperature Incineration, 3C, followed by scrubbing, 2B	Ensure that blockage by polymerization products does not give false indication of empty cylinder or system Avoid PTFE Use other common materials
Halocarbon R1122 C_2HF_2Cl F1	Flammable. Flammability range in air not known High temperature decomposition products are toxic Liquefied gas, bp ca. -19°C, vp ca. 2 bar Gas 3,4 x heavier than air Ethereal odour	Recycling, 1 High temperature Incineration, 3C followed by scrubbing, 2B	Avoid plastic, rubber, etc. with liquid. Use common materials for vapour.

1 Gas EC classification	2 Key characteristics	3 Disposal method	4 Key operational/safety consideration
Halocarbon R1132a $C_2H_2F_2$ A	Flammable, 5,5-21,3 % in air No warning properties High temperature decomposition products are toxic Liquefied gas, bp ca. -84°C, vp ca. 35 bar Gas 2 x heavier than air	Recycling, 1 High temperature Incineration, 3C, followed by scrubbing, 2B	Avoid plastics, rubber etc. with liquid Use common materials for vapour
Halocarbon R1216 C_3F_6 A	Asphyxiant No warning properties High temperature decomposition products are toxic Liquefied gas, bp ca. -30°C, vp ca. 5,5 bar Gas 5 x heavier than air	Recycling, 1 High temperature Incineration, 3C, followed by scrubbing, 2B	Avoid plastics, rubber etc. with liquid Use common materials for vapour
Halocarbon R1318 C_4F_8 A	Asphyxiant Poor warning properties High temperature decomposition products are toxic Liquefied gas, bp ca. +1°C, vp ca. 1 bar Gas 6,5 x heavier than air	Recycling, 1 High temperature Incineration, 3C, followed by scrubbing, 2B	Avoid plastics, rubber etc. with liquid Use common materials for vapour
Helium He A	Asphyxiant No warning properties Gas 7 x lighter than air	Recycling, 1 Direct discharge, 4B Controlled release, 4C Controlled dilution, 4D	Use common materials

1 Gas EC classification	2 Key characteristics	3 Disposal method	4 Key operational/safety consideration
Hexafluoroacetone C_3F_6O T2 C1	Toxic, $LC_{50/1h} = 470$ vpm Corrosive when moist Poor odour warning Liquefied gas, bp ca. $-27^{\circ}C$, vp ca. 6 bar Vapour 6 x heavier than air	Recycling, 1 Direct Discharge to scrubber, 2B	In the event of eye or skin contact, immediately wash with copious amounts of water Use nickel, Monel, stainless steel All equipment shall be precleaned and dry
Hexafluoroisobutene $C_4H_2F_6$ T3	Harmful, $LC_{50/1h} = 2650$ ppm Poor warning properties High temperature decomposition products are toxic Liquefied gas, bp ca. $+14^{\circ}C$, vp ca. 0,2 bar Gas 6 x heavier than air	Recycling, 1 High temperature Incineration, 3C, followed by scrubbing, 2B	Avoid plastics, rubber etc. with liquid Use common materials for vapour
Hydrogen H_2 F1	Flammable, 4,0-75 % in air No warning properties Gas 14 x lighter than air	Recycling, 1 Controlled release, 4C Controlled dilution, 4D Direct combustion, 3A	Ignites very readily, flame barely visible Open valves, etc slowly Use common materials $H_2 + 0,5 O_2 \rightarrow H_2O$ (Method 3A)
Hydrogen bromide HBr T3 C1	Toxic, $LC_{50/1h} = 2860$ vpm Corrosive especially when moist Poor odour warning Liquefied gas, bp ca. $-67^{\circ}C$, vp ca. 22 bar Vapour 3 x heavier than air Good odour warning	Recycling, 1 Controlled release, 4C, followed by Discharge to scrubber, 2A or 2B Discharge to solid-state adsorber, 2C	Ensure blockage by corrosion products does not give false indication of empty cylinder or system Use common materials for dry gas Use Monel, heavy gauge mild steel with moist gas Avoid suckback of water $HBr + OH^- \rightarrow Br^- + H_2O$ (Methods 2A and 2B) Adsorption on soda lime (Method 2C) Sufficient amount of dry diluent gas shall be used to avoid formation of mist, which is difficult to absorb.

1 Gas EC classification	2 Key characteristics	3 Disposal method	4 Key operational/safety consideration
Hydrogen chloride HCl T3 C1	Toxic, $LC_{50/1h} = 2810$ vpm Corrosive especially when moist Liquefied gas, bp ca. -85°C , vp ca. 42 bar Vapour 1,5 x heavier than air Good warning properties	Recycling, 1 Controlled release, 4C, followed by Discharge to scrubber, 2A or 2B Discharge to solid-state adsorber, 2C	Ensure blockage by corrosion products does not give false indication of empty cylinder or system Use common materials for dry gas Use Monel, heavy gauge mild steel if moist Avoid suckback of water $\text{HCl} + \text{OH}^- \rightarrow \text{Cl}^- + \text{H}_2\text{O}$ (Methods 2A and 2B) Adsorption on soda lime (Method 2C) Sufficient amount of dry diluent gas shall be used to avoid formation of mist which is difficult to absorb.
Hydrogen cyanide HCN F1 T1 N1	Very toxic, $LC_{50/1h} = 140$ vpm Fast acting, irreversible, systemic poison Flammable, 6-41 % in air Liquid, bp ca. 26°C , vp ca. 0,8 bar absolute Vapour density similar to air Moderate odour warning (bitter almonds)	Recycling, 1 Discharge to scrubber, 2B Incineration, 3C followed by Discharge to scrubber, 2B	Immediate expert medical attention should be available in case of poisoning. Caution should be exercised when dealing with pure HCN because of its instability and the possibility of an uncontrolled reaction leading to explosion. Avoid suckback of water and catalyst acid or alkalis which promote polymerization (explosion possible) Use stainless steel, Monel and PTFE $2 \text{HCN} + 4 \text{OH}^- + 5 \text{OCl}^- \rightarrow \text{N}_2 + 2 \text{CO}_3^{2-} + 5 \text{Cl}^- + 3 \text{H}_2\text{O}$ (pH > 11) (Method 2B) Burning with hot efficient flame, controlled combustion conditions to minimize NO_2 formation $2 \text{HCN} + 2,5 \text{O}_2 \rightarrow 2 \text{CO}_2 + \text{N}_2 + \text{H}_2\text{O}$ (Method 3C)

1 Gas EC classification	2 Key characteristics	3 Disposal method	4 Key operational/safety consideration
Hydrogen fluoride HF T1 C1	Toxic, LC _{50/1 h} = 966 vpm Corrosive, especially when moist Liquefied gas, bp ca. 20°C, vp ca. 1 bar absolute Vapour density similar to air Moderate odour warning (irritating) with white fumes in air	Recycling, 1 Controlled release, 4C followed by Discharge to scrubber, 2B Discharge to solid-state adsorber, 2C	Attacks and penetrates the skin, causes delayed, severe, deep-seated necrosis If contact with body wash copiously with water and obtain immediate medical attention Ensure blockage by corrosion products does not give false indication of empty cylinder or system Use heavy gauge mild steel, copper and PTFE HF + OH ⁻ → F ⁻ + H ₂ O (Method 2B) Absorption on soda lime (Method 2C) Sufficient amount of dry diluent gas shall be used to avoid formation of mist which is difficult to absorb.
Hydrogen iodide HI T3 C1	Toxic, LC _{50/1 h} = 2860 vpm Corrosive especially when moist Liquefied gas, bp ca. -35°C, vp ca. 7 bar Vapour 4 x heavier than air Good odour warning	Recycling, 1 Controlled release, 4C, followed by Discharge to scrubber, 2A or 2B Discharge to solid-state adsorber, 2C	Ensure blockage by corrosion products does not give false indication of empty cylinder or system Use common materials for dry gas Use Monel, heavy gauge mild steel if moist Avoid suckback of water HI + OH ⁻ → I ⁻ + H ₂ O (Methods 2A and 2B) Adsorption on soda lime (Method 2C)
Hydrogen selenide H ₂ Se F1 T1	Very toxic, LC _{50/1 h} = 2 vpm Flammable 4% to 67.5% Slightly Corrosive Liquefied gas, bp ca. -41°C, vp ca. 8 bar Vapour 3 x heavier than air Good odour warning	Recycling, 1 Incineration, 3C followed by Discharge to scrubber, 2B Discharge to solid-state adsorber, 2C	Elemental selenium can be present in cylinders and lines. Disposal products contain selenic components Use common materials High temperature decomposition products are toxic H ₂ Se + 1,5 O ₂ → SeO ₂ + H ₂ O (Method 3C) SeO ₂ + H ₂ O → H ₂ SeO ₃ (Method 2B) Adsorption on activated charcoal or copper sulphate treated silicagel (Method 2C)

1 Gas EC classification	2 Key characteristics	3 Disposal method	4 Key operational/safety consideration
Hydrogen sulphide H ₂ S F1 T2 N1	Toxic, LC _{50/1 h} = 712 vpm Flammable, 3,9 -45 % in air Corrosive in the presence of moisture Liquefied gas, bp ca. -60°C, vp ca. 17 bar Vapour density similar to air Good odour warning (rotten eggs) initially but decreases with exposure	Recycling, 1 Discharge to scrubber, 2B Incineration, 3C followed by discharge to scrubber, 2B Discharge to solid-state adsorber, 2C	Use aluminium, stainless steel (brass with dry gas) and PTFE $H_2S + OH^- + 4 OCl^- \rightarrow HSO_4^- + 4 Cl^- + H_2O$ (Method 2B) $H_2S + 1,5 O_2 \rightarrow SO_2 + H_2O$ (Method 3C) $SO_2 + 2 OH^- + OCl^- \rightarrow SO_4^{2-} + Cl^- + H_2O$ (Method 2B) Adsorption on soda lime (Method 2C)
Hydrogen telluride H ₂ Te F1 T1	Very toxic, LC _{50/1 h} = 2 vpm Flammable Unstable, decomposes to form elemental tellurium Liquefied gas, bp ca. -2°C, vp ca. 1,5 bar Vapour 4,5 x heavier than air Good odour warning	Recycling, 1 Incineration, 3C followed by Discharge to scrubber, 2B Discharge to solid-state adsorber, 2C	Elemental tellurium can be present in cylinders and lines Disposal products contain telluric components Use Monel, stainless steel or heavy gauge mild steel $H_2Te + 1,5 O_2 \rightarrow TeO_2 + H_2O$ (Method 3C) $TeO_2 + 2 OH^- \rightarrow TeO_3^{2-} + H_2O$ (Method 2B) Adsorption on activated charcoal or copper sulphate treated silicagel (Method 2C)

1 Gas EC classification	2 Key characteristics	3 Disposal method	4 Key operational/safety consideration
Iodine pentafluoride IF ₅ T2 O C1	Toxic, LC _{50/1h} = 120 vpm Powerful oxidizing agent Corrosive especially when moist Liquid, bp ca. 102°C, vp ca. 0,01 bar absolute Good odour warning (irritating)	Recycling, 1 Incineration, 3C followed by Discharge to scrubber, 2B	Extra care! In the event of eye or skin contact immediately wash with copious amounts of water Avoid grease and all other combustible contaminants Use Monel, nickel (heavy gauge mild steel) and PTFE. All equipment to be precleaned and passivated Reacts violently with water Ensure that blockage by corrosion products does not give false indication of empty cylinder or system Introduce initially only small quantities until one is convinced system is passivated Unwanted residual gases shall be securely (Extra care! Seek specialist advice.) contained and safely transported to a facility properly equipped and staffed for disposal. Extra care , seek specialist advice!
Iron pentacarbonyl Fe(CO) ₅ F1 T1	Toxic LC _{50/1h} = 20ppm Spontaneously flammable in air (pyrophoric) Liquid, bp ca. 103°C, vp ca. 0,05 bar absolute No warning properties	Recycling, 1 Combustion/incineration, 3B Incineration, 3C Discharge to solid- state absorber, 2C	Check for propellant Use common materials Dissolved in a combustible solvent: 2 Fe(CO) ₅ + 6.5 O ₂ → Fe ₂ O ₃ + 10 CO ₂ (Methods 3B and 3C) Adsorption on activated charcoal (Method 2C)
Krypton Kr A	Asphyxiant No warning properties Gas 3 x heavier than air	Recycling, 1 Direct discharge, 4B Controlled release, 4C Controlled dilution, 4D	Use common materials
Metal alkyls	Recommended method: Dilute the material to a low concentration (i.e. < 5 %) in a non-reactive hydrocarbon solvent under inert atmosphere. Deactivate by adding a solution of 3-5 % isopropanol in the same solvent. Due to gas evolution during the deactivation process, the apparatus shall be vented. The completion of the reaction can be determined by ceasing of gas generation or heat rise.		

1 Gas EC classification	2 Key characteristics	3 Disposal method	4 Key operational/safety consideration
Methane CH ₄ F1	Flammable, 4,4 -15 % in air Poor warning properties Gas 2 x lighter than air	Recycling, 1 Controlled release, 4C Direct combustion, 3A	Use common materials CH ₄ + 2 O ₂ → CO ₂ + 2 H ₂ O (Method 3A)
Methylacetylene C ₃ H ₄ F1	Flammable, 1,7-12 % in air Subject to exothermic self decomposition Poor warning properties Liquefied gas, bp ca. -23°C, vp ca. 4 bar Vapour 1,5 x heavier than air	Recycling, 1 Direct combustion, 3A Combustion/incineration, 3B	Avoid copper and silver Avoid plastics, rubber etc with liquid Use steel and PTFE Avoid suckback of air C ₃ H ₄ + 4 O ₂ → 3 CO ₂ + 2 H ₂ O (Methods 3A and 3B)
Methylamine CH ₅ N F1 T4	Harmful, LC _{50/1h} = 7000 vpm Flammable, 4,9-20,7 % in air Liquefied gas, bp ca. -6°C, vp ca. 2 bar Vapour density similar to air	Recycling, 1 Direct combustion 3A Incineration, 3C followed by discharge to scrubber, 2B Discharge to scrubber, 2B Discharge to solid-state adsorber, 2C	Use common materials 2 CH ₅ N + 4,5 O ₂ → 2 CO ₂ + N ₂ + 5 H ₂ O Control combustion conditions to minimize NO ₂ production (Methods 3A and 3C) 2 CH ₅ N + H ₂ SO ₄ → 2 CH ₃ NH ₃ ⁺ + SO ₄ ²⁻ (Method 2B) Adsorption on activated charcoal (Method 2C)
3-Methylbutene-1 C ₅ H ₁₀ F1	Flammable, 1,5-9,1 % in air Poor warning properties Liquid, bp ca. 20°C, vp ca. 1 bar absolute Vapour 3 x heavier than air	Recycling, 1 Direct combustion, 3A Combustion/incineration, 3B	Avoid plastics, rubber, etc. with liquid Use common materials for vapour Avoid suckback of air C ₅ H ₁₀ + 7,5 O ₂ → 5 CO ₂ + 5 H ₂ O (Methods 3A and 3B)
Methyl mercaptan CH ₄ S F1 T 3 N	Toxic, LC _{50/1h} = 1350 vpm Flammable, 4,1 -21,8 % in air Liquefied, bp ca.+ 6°C, vp ca. 0,7 bar Vapour 1,5 x heavier than air Good odour warning (rotten eggs)	Recycling, 1 Incineration, 3C followed by Discharge to scrubber, 2B Discharge to solid-state adsorber, 2C	Avoid plastics, rubber, etc. with liquid Use common materials for vapour CH ₄ S + 3 O ₂ → CO ₂ + SO ₂ + 2 H ₂ O (Method 3C) SO ₂ + 2 OH ⁻ → SO ₃ ²⁻ + H ₂ O (Method 2B) Adsorption on activated charcoal (Method 2C)

1 Gas EC classification	2 Key characteristics	3 Disposal method	4 Key operational/safety consideration
Methylsilane CH ₃ SiH ₃ F1	Flammable, 1,3-89 % in air Liquefied gas, bp ca. -57°C, vp 13 bar Vapour 1,5 x heavier than air Good odour warning (repulsive)	Recycling, 1 Incineration, 3C	Use metals and PTFE CH ₃ SiH ₃ + 3,5 O ₂ → SiO ₂ + CO ₂ + 3 H ₂ O (Method 3C)
Mixtures of Gases	See Section 6		
Monochlorosilane SiH ₃ Cl F1 T4 C1	Toxic Spontaneously flammable Corrosive when moist Liquefied gas, bp ca. -30°C, vp ca. 4 bar Vapour 2 x heavier than air Good odour warning (pungent and irritating)	Recycling, 1 Discharge to scrubber, 2B Incineration, 3C followed by Discharge to scrubber, 2B	Discharge as slowly as possible to minimize local heating and risk of ignition. Ensure that blockage by corrosion/combustion products does not give false indication of empty cylinder or system Use common materials for dry gas Use Monel, heavy gauge mild steel if moist Forms hydrochloric acid in presence of water Avoid suckback of aqueous solutions SiH ₃ Cl + 2 NaOH + H ₂ O → Na ₂ SiO ₃ + HCl + 3 H ₂ (Method 2B) HCl + NaOH → NaCl + H ₂ O (Method 2B) SiH ₃ Cl + 1,5 O ₂ → SiO ₂ + HCl + H ₂ O (Method 3C)
Neon Ne A	Asphyxiant No warning properties Gas 1,5 lighter than air	Recycling, 1 Direct discharge, 4B Controlled release, 4C Controlled dilution, 4D	Use common materials
Nickel carbonyl Ni(CO) ₄ F2 T1 N1	Very toxic, LC _{50/1 h} = 20 vpm Flammable, 0,9-64% in air Liquid, bp ca. +43°C vp ca. 0,5 bar absolute No warning properties	Recycling, 1 Combustion/incineration, 3B Discharge to solid-state adsorber, 2C	Extra care! Use common materials Dissolved in a combustible solvent: Ni(CO) ₄ + 2,5 O ₂ → NiO + 4 CO ₂ (Method 3B) Adsorption on activated charcoal (Method 2C)

1 Gas EC classification	2 Key characteristics	3 Disposal method	4 Key operational/safety consideration
Nitric oxide NO O T1 C1	Toxic, LC _{50/1 h} = 115 vpm Oxidizes in air to NO ₂ (and N ₂ O ₃) Gas density similar to air Moderate warning properties	Recycling, 1 Discharge to scrubber, 2B	Use common materials for dry conditions Use stainless steel and PTFE in presence of oxygen and moisture Oxidizing scrubbing solution (permanganate, hypochlorite) is required for high efficiency After oxidation with air: $2 \text{NO}_2 + 2 \text{OH}^- + \text{OCl}^- \rightarrow 2 \text{NO}_3^- + \text{Cl}^- + \text{H}_2\text{O}$ (Method 2B)
Nitrogen N ₂ A	Asphyxiant No warning properties Gas density similar to air	Recycling, 1 Direct discharge, 4A Direct discharge 4B	Use common materials
Nitrogen dioxide NO ₂ O T1 C1	Toxic, LC _{50/1 h} = 115 vpm Corrosive Oxidizing agent Liquefied gas, bp ca. 21°C vp ca. 1 bar absolute Vapour 3 x heavier than air Good odour warning, brown coloured	Recycling, 1 Discharge to scrubber, 2B Discharge to solid-state adsorber, 2C	Avoid plastics, rubber etc. Use stainless steel and PTFE $2 \text{NO}_2 + 2 \text{OH}^- + \text{OCl}^- \rightarrow 2 \text{NO}_3^- + \text{Cl}^- + \text{H}_2\text{O}$ (Method 2B) Absorption on soda lime (Method 2C)
Nitrogen trifluoride NF ₃ O T4	Harmful, LC _{50/1 h} = 6700 vpm Powerful oxidizing agent at elevated temperatures Poor warning properties Gas 2,5 x heavier than air	Recycling, 1	Avoid oil, grease and other combustible contaminants Avoid plastics, rubber, etc. Use other precleaned common materials, PTFE, Kel-F ^R
Nitrogen trioxide N ₂ O ₃ O T1 C1	Very toxic, LC _{50/1 h} = 57 vpm Corrosive Oxidizing agent Critical temperature ca 152°C bp ca 2°C Vapour 2,5 x heavier than air Moderate odour warning	Recycling, 1 Discharge to scrubber, 2B	Avoid plastics, rubber etc. Use stainless steel and PTFE $\text{N}_2\text{O}_3 + 2 \text{OH}^- \rightarrow 2 \text{NO}_2^- + \text{H}_2\text{O}$ (Method 2B)

1 Gas EC classification	2 Key characteristics	3 Disposal method	4 Key operational/safety consideration
Nitrosyl chloride NOCl O T1 C1	Very toxic, LC _{50/1 h} = 35 vpm Corrosive especially when moist Liquefied gas, bp ca. -6°C, vp ca 2,8 bar Vapour 2 x heavier than air Good warning properties	Discharge to scrubber, 2B	Ensure blockage by corrosion products does not give false indication of empty cylinder or system Use nickel, Monel, tantalum, lead, heavy gauge mild steel NOCl + 2 OH ⁻ + OCl ⁻ → NO ₃ ⁻ + 2 Cl ⁻ + H ₂ O (Method 2B)
Nitrous oxide N ₂ O O	Asphyxiant Oxidizing agent Liquefied gas, bp ca. -90°C, vp ca 51 bar Vapour 1,5 x heavier than air	Recycling, 1 Controlled release to atmosphere: 4B, 4C and 4D for small quantities (e.g. in mixtures) or in emergencies	Avoid oil and grease and other combustible contaminants Avoid plastics, rubber etc. with liquid Use common materials for vapour
Oxygen O ₂ O	Powerful oxidant No warning properties Gas density similar to air	Recycling, 1 Direct discharge, 4A Controlled release, 4C	Avoid oil and grease and other combustible contaminants Use precleaned common materials Avoid local oxygen enrichment
Phosgene COCl ₂ T1 C1	Toxic, LC _{50/1 h} = 5 vpm Corrosive especially when moist Poor warning properties Liquefied gas, bp ca. +8°C, vp ca. 0,5 bar Vapour 3 x heavier than air	Recycling, 1 Discharge to scrubber, 2B	Ensure blockage by corrosion products does not give false indication of empty cylinder system Avoid plastics, rubber etc. with liquid Use Monel, stainless steel, heavy gauge mild steel and PTFE COCl ₂ + 4OH ⁻ = CO ₃ ²⁻ + 2Cl ⁻ + 2H ₂ O (Method 2B)
Phosphine PH ₃ F1 T1	Very toxic, LC _{50/1 h} = 20 vpm Flammable: 1,6 to 100% Spontaneously flammable in air (pyrophoric) No odour warning at TLV Liquefied gas, bp ca. -88°C, vp ca. 35 bar Vapour density similar to air	Recycling, 1 Incineration, 3C followed by Discharge to scrubber, 2B	Use common materials 2 PH ₃ + 4 O ₂ → P ₂ O ₅ + 3 H ₂ O (Method 3C) P ₂ O ₅ + 3 H ₂ O → 2 H ₃ PO ₄ (Method 2B) PH ₃ + 4 OCl ⁻ → H ₃ PO ₄ + 4 Cl ⁻ (Method 2B)

1 Gas EC classification	2 Key characteristics	3 Disposal method	4 Key operational/safety consideration
Phosphorus pentafluoride PF ₅ T1 C1	Very toxic, LC _{50/1 h} = 190 vpm Corrosive especially when moist Liquefied gas, bp ca. -85°C, vp ca. 28 bar Vapour odour warning (irritating)	Recycling, 1 Discharge to scrubber, 2B Discharge to solid-state adsorber, 2C	In the event of eye or skin contact, immediately wash with copious amounts of water Use nickel, Monel, heavy gauge mild steel Use hard rubber, PVC for moist gas PF ₅ + 4H ₂ O → H ₃ PO ₄ + 5 HF (Method 2B) Adsorption on soda lime (Method 2C)
Phosphorus trifluoride PF ₃ T2 C1	Toxic, LC _{50/1 h} = 436 vpm Corrosive when moist Liquefied gas, bp ca. -101°C, critical temp. - 2°C	Recycling, 1 Discharge to scrubber, 2B	Use common materials Use alkaline scrubbing solution to ensure rapid hydrolysis PF ₃ + 6 OH ⁻ → PO ₃ ³⁻ + 3 F ⁻ + 3 H ₂ O (Method 2B)
Propadiene C ₃ H ₄ F1	Flammable, 1,9 - 17 % in air Subject to self polymerization Liquefied gas, bp ca. -35°C, vp ca. 6 bar Vapour 1,5 x heavier than air Moderate odour warning	Recycling, 1 Direct combustion, 3A Combustion/incineration, 3B	Guard against polymer blockage, check that content is stable; i.e. that no temperature rises of cylinder Avoid plastics, rubber, etc. with liquid Use common materials for vapour C ₃ H ₄ + 4 O ₂ → 3 CO ₂ + 2 H ₂ O (Methods 3A and 3B)
Propane C ₃ H ₈ F1	Flammable, 1,7 - 9,5 % in air Poor warning properties Liquefied gas, bp ca. -42°C, vp ca. 7,5 bar Vapour 1,5 x heavier than air	Recycling, 1 Direct combustion, 3A Combustion/incineration, 3B	Avoid plastics, rubber etc. with liquid Use common materials for vapour C ₃ H ₈ + 5 O ₂ → 3 CO ₂ + 4 H ₂ O (Methods 3A and 3B)
Propylene C ₃ H ₆ F1	Flammable, 1,8 -10,3 % in air Poor warning properties Liquefied gas, bp ca. -48°C, vp ca. 9,4 bar Vapour 1,5 x heavier than air	Recycling, 1 Direct combustion, 3A Combustion/incineration, 3B	Avoid plastics, rubber etc. with liquid Use common materials for vapour C ₃ H ₆ + 4,5 O ₂ → 3 CO ₂ + 3 H ₂ O (Methods 3A and 3B)

1 Gas EC classification	2 Key characteristics	3 Disposal method	4 Key operational/safety consideration
Propylene oxide C ₃ H ₆ O F1 T4 C2	Harmful, LC _{50/1 h} = 7200 vpm Flammable, 1,9 -24 % in air Vapour can explode by spark, detonation and or heating Subject to exothermic self decomposition and self polymerization Poor warning properties Liquid, bp ca. 34°C, vp ca. 0,6 bar abs. Vapour 2 x heavier than air	Recycling, 1 Combustion/incineration, 3B	Avoid silver and magnesium Avoid plastics, rubber etc. with liquid Use precleaned and dried steel and PTFE Avoid suckback of water, acid, alkali or other catalysts Ensure polymer blockage does not give false indication of empty cylinder or system C ₃ H ₆ O + 4 O ₂ → 3 CO ₂ + 3 H ₂ O (Method 3B)
Selenium hexafluoride SeF ₆ T1 C1	Very toxic, LC _{50/1 h} = 50 vpm Liquefied gas, sublp ca. -47°C, vp ca. 20 bar Vapour 7 x heavier than air	Recycling, 1 Incineration, 3C followed by Discharge to scrubber, 2B	Disposal products contain selenic compounds Use common materials SeF ₆ + fuel + O ₂ → SeO ₂ + 6 HF + + ... (Method 3C) HF + OH ⁻ → F ⁻ + H ₂ O SeO ₂ + OH ⁻ → SeO ⁻ + H ₂ O (Method 2B)
Silane SiH ₄ F1 T4	Spontaneously flammable in air (pyrophoric) 1% Critical temperature -3,5°C Gas density similar to air Good warning properties (flames and smoke)	Recycling, 1 Combustion/Incineration, 3C	Ensure blockage by combustion products goes not give false indication of empty cylinder or system Use common materials SiH ₄ + 2 O ₂ → SiO ₂ + 2 H ₂ O (Method 3C)
Silicon tetrachloride SiCl ₄ T2 C2	Toxic, LC _{50/1 h} = 1312 vpm Corrosive especially when moist Hydrolysis with water or wet air Liquid, bp ca. 58°C, vp ca. 0,3 absolute Vapour 6 x heavier than air Good odour warning	Recycling, 1 Direct Discharge to scrubber, 2A or 2B Discharge to solid-state adsorber, 2C	Avoid plastics, rubber etc. with liquid Use heavy gauge mild steel Ensure blockage by corrosion products does not give false indication of empty cylinder or system SiCl ₄ + 2 H ₂ O → SiO ₂ + 4 HCl (Methods 2A and 2B) Absorption on soda lime (Method 2C)

1 Gas EC classification	2 Key characteristics	3 Disposal method	4 Key operational/safety consideration
Silicon tetrafluoride SiF ₄ T2 C1	Toxic, LC _{50/1 h} = 450 vpm Corrosive especially when moist Gas 3,5 x heavier than air Good odour warning	Recycling, 1 Direct Discharge to scrubber, 2B	Use common materials If contact with body wash copiously with water and obtain immediate medical attention $3 \text{ SiF}_4 + 2 \text{ H}_2\text{O} \rightarrow \text{SiO}_2 + 2 \text{ H}_2\text{SiF}_6$ (Method 2B)
Stibine SbH ₃ F1 T1	Very toxic, LC _{50/1 h} = 20 vpm Spontaneously flammable in air (pyrophoric) Liquefied gas, bp ca. -17°C, vp ca. 5 bar Vapour 4 x heavier than air	Recycling, 1 Discharge to scrubber, 2B Dilution and discharge to scrubber, 4B+2B Discharge to solid-state adsorber, 2C	Use iron or steel Elemental Sb can be present in cylinders or lines. Disposal products contain Sb-com-pounds $\text{SbH}_3 + 4 \text{ H}_2\text{O} \rightarrow \text{SbO}_4^{3-} + 11 \text{ H}^+ + 8 \text{ e}^-$ (Method 2B) The following oxidants can be used: permanganate or hypochlorite Adsorption on activated charcoal or on CuSO ₄ treated silica gel. $3 \text{ CuSO}_4 + 2 \text{ SbH}_3 \rightarrow \text{Cu}_3\text{Sb}_2 + 3 \text{ H}_2\text{SO}_4$ (Method 2C)
Sulphur dioxide SO ₂ T3 C1	Toxic, LC _{50/1 h} = 2520 vpm Corrosive especially when moist Liquefied gas, bp ca. -10°C, vp ca. 2,3 bar Vapour 2 x heavier than air	Recycling, 1 Discharge to scrubber, 2A or 2B Discharge to solid-state adsorber, 2C	Use common materials $\text{SO}_2 + 2 \text{ OH}^- + \text{OCl}^- \rightarrow \text{SO}_4^{2-} + \text{Cl}^- + \text{H}_2\text{O}$ (Methods 2A and 2B) Adsorption on soda lime (Method 2C)
Sulphur hexafluoride SF ₆ A	Asphyxiant No warning properties High temperature decomposition products are toxic Liquefied gas, sublimation point -63,8°C, vp ca. 22 bar Vapour 5 x heavier than air	Recycling, 1	Use common materials
Sulphur tetrafluoride SF ₄ T1 C1	Very toxic, LC _{50/1 h} = 40 vpm Corrosive especially when moist Liquefied gas, bp ca. -40°C, vp ca. 10 bar Vapour 3,5 x heavier than air	Recycling, 1 Discharge to scrubber, 2B Discharge to solid-state adsorber, 2C	If contact with body wash copiously with water and obtain immediate medical attention Avoid plastics, rubber etc. with liquid Use common materials $\text{SF}_4 + 3 \text{ Ca(OH)}_2 \rightarrow 2 \text{ CaF}_2 + \text{CaSO}_4 + \text{H}_2 + 2 \text{ H}_2\text{O}$ (Method 2B) Adsorption on Al(OH) ₃ or soda lime (Method 2C)

1 Gas EC classification	2 Key characteristics	3 Disposal method	4 Key operational/safety consideration
Sulfuryl fluoride SO ₂ F ₂ T3 N1	Toxic, LC _{50/1 h} = 3020 vpm No warning properties Liquefied gas, bp ca. -55°C, vp ca. 15 bar Vapour 3 x heavier than air	Recycling, 1 High temperature Incineration, 3C, followed by scrubbing, 2B	Avoid plastics, rubber etc. with liquid Use common materials
Tetrafluoro- Hydrazine N ₂ F ₄ T1 O	Very toxic, LC _{50/1 h} = 100 vpm Extremely powerful oxidant Explosive self-decomposition possible with heat or shock (pressurized gas) Gas 3,5 x heavier than air	Recycling, 1 Controlled dilution followed by discharge to scrubber, 4B+2B	Unwanted residual gases shall be securely contained and safely transported to a facility properly equipped and staffed for disposal. Extra care , seek specialist advice! Due to extreme reactivity and small quantity normally supplied per cylinder only method recommendable is direct discharge (4B) followed by scrubbing Do not strike or hammer pressurized container Beware of danger of hydrofluoric acid etc. formed (risk of severe, persistent chemical burns) Ensure blockage by corrosion products does not give false indication of empty cylinder or system Avoid all organic materials Use nickel, Monel, stainless steel or heavy gauge mild steel. All equipment shall be pre-cleaned and passivated. Passivate pre-cleaned disposal system by gradually and cautiously increasing flow of tetrafluorohydrazine into continuous diluent stream of nitrogen $\text{N}_2\text{F}_4 + \text{O}_2 + 2 \text{H}_2\text{O} \rightarrow 2 \text{NO}_2 + 4 \text{HF} \rightarrow 2 \text{NO} + 4 \text{F}^-$ (moist air) $2 \text{NO}_2 + 4 \text{HF} \rightarrow 2 \text{NO} + 4 \text{F}^-$ (Method 2B)
Trichlorosilane SiHCl ₃ F1 T4 C1	Toxic, LC _{50/1 h} = 1040 vpm Spontaneously flammable in air (pyrophoric) Liquid, bp ca. 32°C, vp ca. 0,7 bar absolute	Recycling, 1 Discharge to scrubber, 2A or 2B	Ensure that blockage by corrosion/combustion products does not give false indication of empty cylinder or system Use stainless steel, iron, steel or borosilicate glass Avoid contact with oxidizing materials $\text{SiHCl}_3 + 2 \text{NaOH} + \text{H}_2\text{O} \rightarrow \text{Na}_2\text{SiO}_3 + 3 \text{HCl} + \text{H}_2$ (Methods 2A and 2B)

1 Gas EC classification	2 Key characteristics	3 Disposal method	4 Key operational/safety consideration
Trimethylamine C ₃ H ₉ N F1 T4 C2	Harmful, LC _{50/1 h} = 7000 vpm Flammable, 2-11,6 % in air Liquefied gas, bp ca. 3°C, vp ca. 1 bar Vapour 2 x heavier than air Good odour warning (fishlike, ammoniacal)	Recycling, 1 Incineration, 3A or 3C followed by Discharge to scrubber, 2A or 2B Discharge to solid-state adsorber, 2C	Avoid copper, nickel, tin, zinc Avoid plastics, rubber etc. with liquid Use steel and PTFE $2 \text{C}_3\text{H}_9\text{N} + 10,5 \text{O}_2 \rightarrow 6 \text{CO}_2 + 9 \text{H}_2\text{O} + \text{N}_2$ Control to minimize NO ₂ production (Methods 3 A and 3C) $2 (\text{CH}_3)_3\text{N} + \text{H}_2\text{SO}_4 \rightarrow 2 (\text{CH}_3)_3\text{NH}^+ + \text{SO}_4^{2-}$ (Methods 2A and 2B) Adsorption on activated charcoal (Method 2C)
Trimethylsilane (CH ₃) ₃ SiH F1	Flammable, 1,3 - 44 % in air Liquefied gas, bp ca. 7°C, vp ca. 0,6 bar Vapour 3 x heavier than air	Combustion/Incineration, 3C	Ensure that blockage by combustion products does not give false indication of empty cylinder or system Use common materials $(\text{CH}_3)_3\text{SiH} + 6,5 \text{O}_2 \rightarrow 3 \text{CO}_2 + \text{SiO}_2 + 5 \text{H}_2\text{O}$
Tungsten hexafluoride WF ₆ T1 C1	Very toxic, LC _{50/1 h} = 160 vpm Corrosive Liquefied gas, bp ca. +17°C, vp ca. 0,2 bar Vapour 11 x heavier than air	Recycling, 1 Discharge to scrubber, 2B Direct discharge to solid-state adsorber, 2C	In the event of eye or skin contact, immediately wash with copious amounts of water Avoid plastic, rubber, etc with liquid $\text{WF}_6 + 4 \text{Ba}(\text{OH})_2 \rightarrow \text{BaWO}_4 + 3 \text{BaF}_2 + 4 \text{H}_2\text{O}$ (Method 2B) $\text{WF}_6 + 4 \text{CaO} \rightarrow \text{CaWO}_4 + 3 \text{CaF}_2$ or $3 \text{WF}_6 + 4 \text{Al}_2\text{O}_3 \rightarrow \text{Al}_2(\text{WO}_4)_3 + 6 \text{AlF}_3$ (Examples of Method 2C)
Vinyl bromide C ₂ H ₃ Br F1	Harmful, LC _{50/1 h} > 5000 vpm Flammable, 5,6 -15 % in air Poor warning properties Liquefied gas, bp ca. 16°C, vp ca. 0,2 bar Vapour 4 x heavier than air	Recycling, 1 Incineration, 3C followed by Discharge to scrubber, 2B	Avoid copper and silver if C ₂ H ₂ is present or as an impurity Avoid plastics, rubber etc with liquid Use common materials $\text{C}_2\text{H}_3\text{Br} + 2,5 \text{O}_2 \rightarrow 2 \text{CO}_2 + \text{HBr} + \text{H}_2\text{O}$ (Method 3C) $\text{HBr} + \text{OH}^- \rightarrow \text{Br}^- + \text{H}_2\text{O}$ (Method 2B)
Vinyl chloride C ₂ H ₃ Cl F1	Carcinogenic, Not acute toxic Flammable, 3,8-31 % in air Poor warning properties Liquefied gas, bp ca. -14°C, vp ca. 2,3 bar Vapour 2 x heavier than air	Recycling, 1 Incineration, 3C followed by Discharge to scrubber, 2B	Avoid copper and silver if C ₂ H ₂ is present or as an impurity Avoid plastics, rubber etc. with liquid Use other common materials $\text{C}_2\text{H}_3\text{Cl} + 2,5 \text{O}_2 \rightarrow 2 \text{CO}_2 + \text{HCl} + \text{H}_2\text{O}$ (Method 3C) $\text{HCl} + \text{OH}^- \rightarrow \text{Cl}^- + \text{H}_2\text{O}$ (Method 2B)

1 Gas EC classification	2 Key characteristics	3 Disposal method	4 Key operational/safety consideration
Vinyl fluoride C_2H_3F F1	Flammable, 2,9 -21,7 % in air No warning properties High temperature decomposition products are toxic Liquefied gas, bp ca. -72°C, vp ca. 26 bar Vapour 1,5 x heavier than air	Recycling, 1 Incineration, 3C followed by Discharge to scrubber, 2B	Avoid copper and silver if C_2H_2 is present or as an impurity Avoid plastics, rubber etc. with liquid Use other common materials Use other common materials $C_2H_3F + 2,5 O_2 \rightarrow 2 CO_2 + HF + H_2O$ (Method 3C) $HF + OH^- \rightarrow F^- + H_2O$ (Method 2B)
Vinyl methyl ether C_3H_6O F1	Flammable, 2,2 -39 % in air Poor warning properties Liquefied gas, bp ca. 6°C, vp ca. 0,7 bar Vapour 2 x heavier than air	Recycling, 1 Direct combustion, 3A Combustion/incineration, 3B	Avoid copper and silver if C_2H_2 is present or as an impurity Avoid plastics, rubber etc. with liquid $C_3H_6O + 4 O_2 \rightarrow 3 CO_2 + 3 H_2O$ (Methods 3A and 3B)
Xenon Xe A	Asphyxiant No warning properties Critical temperature 16°C Gas 4,5 x heavier than air	Recycling, 1 Direct discharge, 4B	Use common materials

Annex 2 - Index to gas names and synonyms

The purpose of this section is to assist with the identification of gases in those instances, where unfamiliar synonyms or German, French or Spanish names are used.

The first column of the index gives the English name of the gas.

The most familiar or the usual name is shown in upper case type and it is this name which is used in the gas characteristics table in Annex 1.

Synonyms are shown in lower case type - with the "usual" names shown in second column.

French, German and Spanish names are given in the last three columns.
Again the "usual" names are shown in upper case types, followed in lower case by any synonyms.

English name	Formula and Synonym(s)	French name Synonym (s)	German name and synonym(s)	Spanish name and synonym(s)
ACETYLENE	C ₂ H ₂ - Ethyne	ACETYLENE	ACETYLEN - Azetylen - Ethin - Aethin - Äthin - Dissousgas	ACETILENO
Allene	- PROPADIENE			
AMMONIA	NH ₃	AMMONIAC	AMMONIAK	AMONIACO
Antimony hydride	- STIBINE			
ARGON	Ar	ARGON	ARGON	ARGÓN
ARSENIC PENTAFLUORIDE	AsF ₅		ARSEN PENTAFLU ORID	
ARSENIC TRIFLUORIDE	AsF ₃		ARSENTRIFLUORI D	
Arsenic trihydride	- ARSINE			
ARSINE	AsH ₃ - Hydrogen arsenide - Arsenic trihydride	ARSINE - Arséniure d'hydrogène - Hydrogène arsenié	ARSENWASSERST OFF - Arsin	ARSINA - Arsenura de hidrogeno
BORON TRIBROMIDE	BBr ₃	TRIBROMURE DE BORE	BORTRIBROMID	TRIBROMURO DE BORO
BORON TRICHLORIDE	BCl ₃	TRICHLORURE DE BORE	BORTRICHLORID	TRICLORURO DE BORO
BORON TRIFLUORIDE	BF ₃	TRIFLUORURE DE BORE	BORTRIFLUORID	TRIFLUORURO DE BORO
BROMINE TRIFLUORIDE	BrF ₃	TRIFLUORURE DE BROME	BROMTRIFLUORID	TRIFLUORURO DE BROMO
Bromochlorodifluorome thane	- HALOCARBON R12B1			
Bromoethylene	- VINYL BROMIDE			
BROMOMETHANE	CH ₃ Br - Methyl bromide - Halocarbon R40B1	MONOBROMOME TANE - Bromométhane - Bromure de methylé - Réfrigérant 40B1	BROMMETHAN - Methylbromid	MONOBROMOMET ANO - Bromo metano - Bromuro de metilo
Bromotrifluoroethylene	- HALOCARBON R113B1			
Bromotrifluoromethane	- HALOCARBON R13B1			
1,2-BUTADIENE	C ₄ H ₆		BUTADIEN-1,2	BUTADIENO-1,2
1,3-BUTADIENE	C ₄ H ₆	BUTADIENE-1,3 - Divinyle - Erithrène - Vinyléthylène	BUTADIEN-1,3 - Divinyl	BUTADIENO-1,3 - Divinilo - Eritreno - Viniletileno

English name	Formula and Synonym(s)	French name Synonym (s)	German name and synonym(s)	Spanish name and synonym(s)
n-BUTANE	C ₄ H ₁₀	n-BUTANE - Butane	n-BUTAN - Butan	n-BUTANO - Butano
ISOBUTANE	C ₄ H ₁₀	ISOBUTANE - méthyl propane	ISOBUTAN - 2-Methylpropan	ISOBUTANO - Metil propano
1-BUTENE	C ₄ H ₈ - 1-Butylene	BUTENE - Butène	BUTEN-1 - 1-Butylen - Butylene	BUTENO-1 - Buteno
Cis-2-BUTENE	C ₄ H ₈ - Cis-2-butylene	Cis-BUTENE-2 - Cis-butène - Cis-butylène	Cis-BUTEN-2 - Cis-2-Butylen	Cis-BUTENO-2 - Cis-buteno - Cis-butileno
Trans-2-BUTENE	C ₄ H ₈ - Trans-2-butylene	Trans-BUTENE-2 - Trans-butène - Trans-butylène	Trans-BUTEN-2 - Trans-2-Butylene	Trans-BUTENO-2 - Trans-buteno - Trans-butileno
ISOBUTENE	C ₄ H ₈ - Isobutylene	ISOBUTENE - Isobutylène - Methylpropène	ISOBUTEN - Isobutylen - 2-Methylpropen	ISOBUTENO - Isobutileno - Metil propeno
1-Butylene	- 1-BUTENE			
Cis-2-Butylene	- Cis-2-BUTENE			
Trans-2-Butylene	- Trans-2-BUTENE			
Isobutylene	- ISOBUTENE			
Butyne	ETHYLACETYLEN E			
CARBON DIOXIDE	CO ₂ - Carbonic acid anhydride	DIOXYDE DE CARBONE - Anhydride carbonique	KOHLENDIOXYD - Kohlensäure -Kohlensäure- anhydrid	DIÓXIDO DE CARBONO - Anhídrido carbónico
CARBON MONOXIDE	CO	MONOXYDE DE CARBONE- Oxyde de carbone	KOHLENMONOXID - Kohlenoxid	MONÓXIDO OE CARBONO - Oxido de carbono
Carbon tetrafluoride	- HALOCARBON R14			
Carbonic acid anhydride	- CARBON DIOXIDE			
Carbonyl chloride	- PHOSGENE			
CARBONYL FLUORIDE	COF ₂	FLUORURE DE CARBONYLE	CARBONYLFLUORI D	FLUORURO DE CARBONILO
CARBONYL SULPHIDE	COS	SULFURE DE CARBONYLE - Oxsulfure de carbone	CARBONYLSULFID - Kohlenoxidsulfid	SULFURO DE CARBONILO - Oxisulfuro de carbono
CHLORINE	Cl ₂	CHLORE	CHLOR - Chlorgas	COLORO
CHLORINE PENTAFLUORIDE	ClF ₅	CHLORPENTAFL UORID		
CHLORINE TRIFLUORIDE	ClF ₃	TRIFLUORURE DE CHLORE	CHLORTRIFLUORI D	TRIFLUORURO DE CLORO
Chlorodifluoroethane	- HALOCARBON R142b			
Chlorodifluoroethene	- HALOCARBON R1122			
Chlorodifluoromethane	- HALOCARBON R22			
CHLOROETHANE	C ₂ H ₅ Cl - Chloroethane - Ethylchloride - Halocarbon - R 160	MONOCHLORO ETHANE - Chlorure d'éthyle - Réfrigérant 160	CHLORETHAN - R 160	MONOCLOROETA NO - Cloroetano - Refrigerante 160 - Cloruro de etilo
Chloroethylene	- VINYL CHLORIDE			
CHLOROMETHANE	- Halocarbon R40 - Methyl chloride	MONOCHLOROM ETHANE - Chlorométhane - Chlorure de méthyle - Réfrigérant 40	CHLORMETHAN - Methylchlorid - R 40	MONOCLOROMET ANO - Clorometano - Cloruro de metilo - Refrigerante 40

English name	Formula and Synonym(s)	French name Synonym (s)	German name and synonym(s)	Spanish name and synonym(s)
Chloropentafluoroethane	- HALOCARBON R115			
Chlorotetrafluoroethane	- HALOCARBON R124a			
Chlorotrifluoroethane	- HALOCARBON R133a			
Chlorotrifluoroethene	- HALOCARBON R1113			
Chlorotrifluoromethane	- HALOCARBON R13			
CYANOGEN	C ₂ N ₂	CYANOGENE	DICYAN - Cyanogen	CIANOGENO
CYANOGEN CHLORIDE	C ₂ N ₂ Cl ₂ or CNCl	CHLORURE DE CYANOGENE	CHLORCYAN - Chlordicyan - Cyanogenchlorid	CLORURO DE CIANOGENO
CYCLOBUTANE	C ₄ H ₈			
CYCLOPROPANE	C ₃ H ₆	CYCLOPROPANE - Triméthylène	CYCLOPROPAN	CICLOPROPANO - Trimetilo
DEUTERIUM	D ₂	DEUTERIUM	DEUTERIUM - Schwerer Wasserstoff	DEUTERIO
DIBORANE	B ₂ H ₆	DIBORANE	DIBORAN	DIBORANO
Dibromodifluoromethane	- HALOCARBON R12B2			
Dibromotetrafluoroethane	- HALOCARBON R114B2			
Dichlorodifluoromethane	- HALOCARBON R12			
Dichlorofluoromethane	- HALOCARBON R21			
DICHLOROSILANE	SiH ₂ Cl ₂	DICHLOROSILAN E	DICHLORSILAN	DICLOROSILANO
Dichlorotetrafluoroethane	- HALOCARBON R114			
1,1-Difluoroethane	- HALOCARBON R152a			
1,1-Difluoroethylene	- HALOCARBON R1132a			
DIMETHYLAMINE	C ₂ H ₇ N	DIMETHYLAMINE	DIMETHYLAMIN	DIMETILAMINA
DIMETHYL ETHER	C ₂ H ₆ O	ETHER METHYLIQUE - Oxyde de méthyle - Oxyde de diméthyle	DIMETHYLETHER - Methylether	DIMETIL ETER - Óxido de dimetilo - Óxido dimetilo
2,2- DIMETHYLPROPANE	C ₅ H ₁₂ - Neopentane	DIMETHYL-2,2- PROPANE - Diméthyl propane - Néopentane Tétraméthylméthane	2,2- DIMETHYLPROPAN - Neopentan	DIMETIL-2,2- PROPANO - Tetrametil metano
DIMETHYL SILANE	(CH ₃) ₂ SiH ₂		DIMETILSILAN	
DISILANE	Si ₂ H ₆		DISILAN	
Dinitrogen tetroxide	- NITROGEN DIOXIDE			
Epoxyethane	- ETHYLENE OXIDE			
Epoxypropane	- PROPYLENE OXIDE			
ETHANE	C ₂ H ₆	ETHANE	ETHAN	ETANO
Ethene	- ETHYLENE			
ETHYLACETYLENE	C ₄ H ₆ - Butyne-1	BUTYNE-1 - Butyne - Ethylacetylene	BUTIN-1 - Ethylacetylen	BUTINO-1 - Butino - Etilacetileno
Ethyl chloride	- CHLOROETHANE			

English name	Formula and Synonym(s)	French name Synonym (s)	German name and synonym(s)	Spanish name and synonym(s)
ETHYLAMINE	C ₂ H ₇ N	MONOETHYLAMI NE - Ethylamine	ETHYLAMIN	MONOETILAMINA - Etilamina
ETHYLENE	C ₂ H ₄ - Ethene	ETHYLENE - Ethène	ETHEN - Äthylen - Äthen	ETILENO - Eteno
ETHYLENE OXIDE	C ₂ H ₄ O - Oxirane - Epoxyethane	OXYDE D'ETHYLENE - Oxirane	ETHYLENOXID - Oxiran	OXIDO DE ETILENO - Oxirano
Ethylene difluoride	- HALOCARBON R152a			
Ethyl fluoride	- FLUOROETHANE			
Ethyne	- ACETYLENE			
FLUORINE	F ₂	FLUOR	FLUOR	FLUOR
FLUOROETHANE	C ₂ H ₅ F - Halocarbon R161 - Ethyl fluoride	MONOFLUROET HANE - Fluoroéthane - Fluorure d'éthyle - Réfrigérant 161	FLUORETHAN - Ethylfluorid - Monofluorethan - R 161	MONOFLUROETA NO - Fluoretano - Fluoruro de etilo - Refrigerante 161
Fluoroethylene	VINYL FLUORIDE			
Fluoroform	HALOCARBON R23			
FLUOROMETHANE	CH ₃ F - Methylfluoride - Halocarbon R41	MONOFLUOROM ETHANE - Fluorométhane - Fluorure de méthyle - Réfrigérant 41	FLUORMETHAN - Methylfluorid - R 41	MONOFLURO METANO - Fluormetano - Fluoruro de metilo - Refrigerante 41
GERMANE	GeH ₄	GERMANE - Monogermane - Hydrogen germanié	GERMANIUM- WASSERSTOFF - German	GERMANIO - Hidrogeno germaniado
HALOCARBON R11	CCl ₃ F Trichlorofluoromet hane	TRICHLOROFLUO ROMETHANE - Réfrigérant 11	TRICHLORFLUOR METHAN - R 11	TRICLOROFLUOR OMETANO - Refrigerante 11
HALOCARBON R12	CCl ₂ F ₂ Dichlorodifluoromet hane	DICHLORODIFLU OROMETHANE - Réfrigérant 12	DICHLORDIFLUOR METHAN - R 12	DICLORODIFLUOR OMETANO - Refrigerante 12
HALOCARBON R12B1	CBrClF ₂ Bromochlorodifluor omethane	BROMOCHLORO DIFLUOR- METHANE - Réfrigérant 12B1	BROMCHLORDIFL UOR- METHAN - R 12B1	BROMOCLORODIF LUORO- METANO - Refrigerante 12B1
HALOCARBON R12B2	CBr ₂ F ₂ Dibromodifluorome thane	DIBROMODIFLUO ROMETHANE - Réfrigérant 12B2	DIBROMDIFLUORM ETHAN - R 12B2	DIBROMODIFLUOR OMETANO - Refrigerante 12B2
HALOCARBON R13	CClF ₃ Chlorotrifluoromet hane	CHLOROTRIFLUO ROMETHANE - Réfrigérant 13	CHLORTRIFLUOR METHAN - R 13	CLOROTRIFLUOR OMETANO - Refrigerante 13
HALOCARBON R13B1	CBrF ₃ Bromotrifluoromet hane	BROMOTRIFLUO ROMETHANE - Réfrigérant 13B1	BROMTRIFLUORM ETHAN - R 13B1	BROMOTRIFLUOR OETANO - Refrigerante 13B1
HALOCARBON R14	CF ₄ Carbon tetrafluoride Tetrafluoromethan e	TETRAFLUORUR E DE CARBONE Tetrafluorométhan e Réfrigérant 14	TETRAFLUORMET HAN - R 14	TETRAFLUORURO DE CARBONO - Refrigerante 14 - Tetrafluor metano
HALOCARBON R21	CHCl ₂ F - Dichlorofluoromet hane	DICHLOROFLUO ROMETHANE - Réfrigérant 21	DICHLORFLUORM ETHAN - R 21	DICLOROFLURO METANO - Refrigerante 21
HALOCARCON R22	CHClF ₂ - Chlorodifluoromet hane	CHLORODIFLUO ROMETHANE - Réfrigérant 22	CHLORDIFLUORM ETHAN - R 22	CLORODIFLUORO METANO - Refrigerante 22

English name	Formula and Synonym(s)	French name Synonym (s)	German name and synonym(s)	Spanish name and synonym(s)
HALOCARBON R23	CHF ₃ - Fluoroform - Trifluoromethane	TRIFLUOROETHANE - Fluoroforme - Réfrigérant 23	TRIFLUORMETHAN - R 23	TRIFLUOROMETANO - Fluoroformo - Refrigerante 23
Halocarbon R40	- CHLOROMETHANE			
Halocarbon R40B1	- BROMOMETHANE			
Halocarbon R41	- FLUOROMETHANE			
HALOCARBON R113	C ₂ Cl ₃ F ₃ - Trichlorotrifluoroethane	TRICHLOROTRIFLUOROETHANE - Réfrigérant 113	TRICHLOROTRIFLUORETHAN - R 113	TRICHLOROTRIFLUOROETANO - Refrigerante 113
HALOCARBON R114	C ₂ Cl ₂ F ₄ Dichlorotetrafluoroethane	DICHLORO-1,2-TETRAFLUOROETHANE Dichlorotetrafluoroéthane - Réfrigérant 114	1,2-DICHLORTETRAFLUORETHAN - R 114	DICHLORO-1,2-TETRAFLUOROETANO - Diclorotetrafluoroetano
HALOCARBON R114B2	C ₂ Br ₂ F ₄ Dibromotetrafluoroethane	DIBROMO-1,2-TETRAFLUOROETHANE Dibromotetrafluoroéthane	1,2-DIBROMTETRAFLUORETHAN R 114B2 Halon 2402	DIBROMO-1,2-TETRAFLUOROETANO Dibromotetrafluoroetano
HALOCARBON R115	C ₂ ClF ₅ Chloropentafluoroethane	CHLOROPENTAFLUOROETHANE - Réfrigérant 115	CHLORPENTAFLUORETHAN - R 115	CLOROPENTAFLUROETANO - Refrigerante 115
HALOCARBON R116	C ₂ F ₆ - Hexafluoroethane - Perfluoroethane	HEXAFLUROETHANE - Réfrigérant 116	HEXAFLUROETHAN - R 116	HEXAFLUROETANO - Refrigerante 116
HALOCARBON R124a	C ₂ H ₄ Cl Chlorotetrafluoroethane		1-CHLOR-1,1,2,2-TETRAFLUROETHAN	
HALOCARBON R133a	C ₂ H ₂ F ₃ Cl Chlorotrifluoroethane		1-CHLOR-2,2,2-TRIFLUORETHAN	
HALOCARBON R142b	C ₂ H ₃ ClF ₂ Chlorodifluoroethane	CHLORO-1-DIFLUORO-1,1-ETHANE Chlorodifluoroéthane - Réfrigérant 142b	1-CHLOR-1,1-DIFLUORETHAN - R 142b	CLORO-1,1-DIFLUORO-1,1-ETANO - Refrigerante 142b
HALOCARBON R143a	C ₂ H ₃ F ₃ - Trifluoroethane		TRIFLUORETHAN	TRIFLUOROETANO
HALOCARBON R152a	C ₂ H ₄ F ₂ - Difluoroethane - Ethylenedifluoride	DIFLUORO-1,1-ETHANE - Difluoroéthane - Fluorure d'éthylidène - Réfrigérant 152a	1,1-DIFLUORETHAN - Difluorethan - R 152a	DIFLUORO-1,1-ETANO - Difluoretano - Fluoruro de etilideno - Refrigerante 152a
Halocarbon R160	CHLOROETHANE			CLOROETANO
Halocarbon R161	FLUROETHANE			FLUROETANO
HALOCARBON R218	C ₃ F ₈ - Octafluoropropane - Perfluoropropane	OCTOFLUROPROPANE - Perfluoropropane - Réfrigérant 218	OCTAFLUROPROPAN - R 218	OCTOFLUROPROPANO - Perfluoropropano - Refrigerante 218
HALOCARBON R227	C ₃ HF ₇ - Heptafluoropropane			HEPTAFLUROPROPANO

English name	Formula and Synonym(s)	French name Synonym (s)	German name and synonym(s)	Spanish name and synonym(s)
HALOCARBON C318	C ₄ F ₈ - Octafluorocyclobutane	OCTOFLUOROCYCLOBUTANE - Perfluorocyclobutane - Réfrigérant C 318	OCTAFLUOROCYCLOBUTAN - RC 318	OCTAFLUOROCICLOBUTANO - Perfluorociclobutano - Refrigerante C 318
HALOCARBON R1113	C ₂ ClF ₃ - Chlorotrifluoroethene	CHLOROTRIFLUOROETHYLENE - Réfrigérant 1113	CHLOROTRIFLUORETHEN - R 1113	CHLOROTRIFLUOROETILENO - Refrigerante 1113
HALOCARBON R113B1	C ₂ BrF ₃ Bromotrifluoroethene Trifluorovinylbromide	BROMOTRIFLUOROETHYLENE - Réfrigérant 1113B1	BROMOTRIFLUORETHEN - R 1113B1	BROMOTRIFLUOROETILENO - Refrigerante 1113B1
HALOCARBON R1114	C ₂ F ₄ - Tetrafluoroethene	TETRAFLUOROETHYLENE - Réfrigérant 1114	TETRAFLUORETHEN - R 1114	TETRAFLUOROETILENO - Refrigerante 1114
HALOCARBON R1122	C ₂ HF ₂ Cl Chlorodifluoroethene		CHLORODIFLUORETHEN	
HALOCARBON R1132a	C ₂ H ₂ F ₂ Difluoroethene	DIFLUORO-1,1-ETHYLENE - Difluoroéthylène - Fluorure de vinylidène - Réfrigérant 1132a	1,1-DIFLUORETHEN - Difluoretylen - Vinylidenfluorid - R 1132a	DIFLUORO-1,1-ETILENO - Difluor etileno - Fluoruro de vinilideno
Halocarbon R1140	VINYL CHLORIDE			
Halocarbon R1140B1	VINYL BROMIDE			
Halocarbon R1141	VINYL FLUORIDE			
HALOCARBON R1216	C ₃ F ₆ Hexafluoropropene - Perfluoropropene	HEXAFLUOROPROPYLENE Hexafluoropropène Perfluoropropylène Réfrigérant 1216	HEXAFLUORPROPEN Perfluorpropylen	HEXAFLURO DE PROPILENO Hexafluorpropeno Perfluorpropileno Refrigerante 1216
HALOCARBON R1318	C ₄ F ₈ Perfluorobutene-2	OCTOFLUOROBUTENE-2 - Octofluorobutène - Perfluorobutène-2 - Réfrigérant 1318	OCTAFLUORBUTEN-2 - Octafluorbuten	OCTAFLURO BUTENO-2 - Octofluorbuteno - Perfluorbuteno - Refrigerante 1318
HALOCARBON R1336	C ₄ H ₂ F ₆ Hexafluoroisobutene		HEXAFLUORISOBUTEN	HEXAFLUROISOBUTENO
HELIUM	He	HELIUM	HELIUM	HELIO
HEXAFLUROACETONE	C ₃ F ₆ O	HEXAFLUROACETONE	HEXAFLURACETON	HEXAFLURACETONA
Heptafluoropropane	HALOCARBON R227			
Hexafluoroethane	HALOCARBON R116			
HEXAFLUROISOBUTENE	Halocarbon R1336			
Hexafluoropropene	HALOCARBON R1216			
Hydrobromic acid (anhydrous)	- HYDROGEN BROMIDE			
Hydrochloric acid (anhydrous)	- HYDROGEN CHLORIDE			
Hydrocyanic acid (anhydrous)	- HYDROGEN CYANIDE			
Hydrofluoric acid (anhydrous)	- HYDROGEN FLUORIDE			
HYDROGEN	H ₂	HYDROGENE	WASSERSTOFF	HIDRÓGENO
Hydrogen antimonide	STIBINE			
Hydrogen arsenide	ARSINE			

English name	Formula and Synonym(s)	French name Synonym (s)	German name and synonym(s)	Spanish name and synonym(s)
HYDROGEN BROMIDE	HBr Hydrobromic acid (anhydrous)	BROMURE D'HYDROGENE Acide bromhydrique anhydre Gaz bromhydrique	BROMWASSERST OFF	BROMURO DE HIDRÓGENO - Acido bromhidrico anhidro - Gas bromhidrico
HYDROGEN CHLORIDE	HCl Hydrochloric acid (anhydrous)	CHLORURE D'HYDROGENE - Acide chlorhydrique anhydre - Gaz chlorhydrique	CHLORWASSERST OFF - Salzsäure	CLORURO DE HIDRÓGENO - Acido clorhidrico anhidro - Gas clorhidrico
HYDROGEN CYANIDE	HCN Hydrocyanic acid (anhydrous)	CYANURE D'HYDROGENE - Acide cyanhydrique anhydre - Gaz cyanhydrique	CYANWASSERSTO FF - Blausäure	CIANURO DE HIDRÓGENO - Acido cianhidrico anhidro - Gas cianhidrico - Acido prúsico
HYDROGEN FLUORIDE	HF Hydrofluoric acid (anhydrous)	FLUORURE D'HYDROGENE - Acide fluorhydrique anhydre - Gaz fluorhydrique	FLUORWASSERST OFF - Flusssäure	FLUORURO DE HIDRÓGENO - Acido fluorhidrico anhidro - Gas fluorhidrico
HYDROGEN IODIDE	HI	IODURE D'HYDROGENE - Acide iodhydrique anhydre - Gaz fluorhydrique	JODWASSERSTOF F	IODURO OE HIDRÓGENO - Acido ioddrico anhidro - Gas iodídrico
Hydrogen phosphide	PHOSPHINE			
HYDROGEN SELENIDE	H ₂ Se - Selenium hydride	SELENIURE D'HYDROGENE - Hydrogène sélénié	SELENWASSERST OFF	SELENIURO DE HIDRÓGENO - Hidrogeno seleniado
HYDROGEN SULPHIDE	H ₂ S - Sulphuretted hydrogen	SULFURE D'HYDROGENE Hydrogène sulfuré	SCHWEFELWASSE RSTOFF	SULFURO DE HIDRÓGENO - Hidrógeno sulfurado - Sulfídrico
HYDROGEN TELLURIDE	H ₂ Te	HYDROGENE TELLURE - Tellurure d'hydrogène	TELLURWASSERS TOFF	HIDRÓGENO
IODINE PENTAFLUORIDE	IF ₅	PENTAFLUORUR E D'IODE	JODPENTAFLUORI D	PENTAFLUORURO DE IODO
IRON PENTACARBONYL	Fe(CO) ₅	FER PENTACARBONY LE	EISENPENTACARB ONYL	HIERRO PENTA CARBONILO
KRYPTON	Kr	KRYPTON	KRYPTON	KRIPTON
Laughing gas	NITROUS OXIDE			
METHANE	CH ₄	METHANE	METHAN	METANO
Methanethiol	METHYLMERCAP TAN			
Methyl ethyl ether	ETHYL METHYL ETHER			
METHYLACETYLENE	C ₃ H ₄ Propyne	PROPYNE - Methyl acétylène	METHYLACETYLE N - Propin	PROPINO - Metilacetileno
METHYLAMINE	CH ₅ N	MONOMETHYLA MINE	METHYLAMIN	MONOMETIL AMINA
Methyl bromide	BROMOMETHANE			
3-METHYLBUTENE-1	C ₅ H ₁₀ Isopentene	METHYL-3- BUTENE-1 - Iso Amylène - Iso Pentène	3-METHYLBUTEN-1	METIL-3-BUTENO-I - Iso amilo - Iso penteno

English name	Formula and Synonym(s)	French name Synonym (s)	German name and synonym(s)	Spanish name and synonym(s)
Methyl chloride	CHLOROMETHAN E			
Methylfluoride	FLUOROMETHAN E			
METHYLMERCAPTAN	CH ₄ S Methanethiol	METHYLMERCAP TAN - Methanethiol	METHYLMERCAPT AN	METILMERCAPTAN O - Metanotiol
Methyloxirane	1,2-PROPYLENE OXIDE			
Methylpropane	ISOBUTANE			
Methyl propene	ISOBUTENE			
METHYLSILANE	SiCH ₆	MONOMETHYLSIL ANE	METHYLSILAN	MONOMETILSILAN O
Methylvinylether	VINYL METHYL ETHER			
MONOCHLOROSILAN E	SiH ₃ Cl	MONOCHLOROSI LANE	CHLORSILAN	MONOCLOROSILA NO
NEON	Ne	NEON	NEON	NEON
Neopentane	- 2,2-DIMETHYL PROPANE			
NICKEL CARBONYL	Ni(CO) ₄	NICKELTETRACA RBONYLE - Nickel carbonyle	NICKELTETRACAR BONYL - Nickelcarbonyl	NIQUELTETRACAR BONILO
NITRIC OXIDE	NO	MONOXYDE D'AZOTE - Bioxyde d'azote - Oxyde azotique	STICKSTOFFMON OXID - Stickstoffoxid	MONOXIDO DE NITRÓGENO - Oxido nítrico - Bioxido de nitrógeno
NITROGEN	N ₂	AZOTE	STICKSTOFF	NITRÓGENO
NITROGEN DIOXIDE	NO ₂ (or N ₂ O ₄) Dinitrogen tetroxide	DIOXYDE D'AZOTE - Hémitéroxide d'azote - Péroxyde d'azote	STICKSTOFFDIOXI D - Stickstofftetroxid - Distickstofftetroxid	TETRAOXIDO DE DINITRÓGENO - Dioxide de nitrógeno - Peroxid de nitrógeno - Hemitetroxide de nitrógeno
NITROGEN TRIFLUORIDE	NF ₃	TRIFLUORURE D'AZOTE	STICKSTOFFTRIFL UORID - Fluorstickstoff	TRIFLUORURO DE NITRÓGENO
NITROGEN TRIOXIDE	N ₂ O ₃	SESQUIOXYDE D'AZOTE - Anhydride nitreux	STICKSTOFFTRIOX ID	TRIOXIDO DE NITRÓGENO - Sesquióxido de nitrógeno - Anhídrido nitroso - Anhídrido nítrico
NITROSYLCHLORIDE	NOCI	CHLORURE DE NITROSYLE	NITROSYLCHLORI D	CLORURO DE NITROSILO
NITROUS OXIDE	N ₂ O Laughing gas	PROTOXYDE D'AZOTE - Hémiroxyde d'azote - Oxyde azoteux	DISTICKSTOFFOXI D - Stickoxydul - Lachgas	PROTÓXIDO DE NITRÓGENO - Hemióxido de nitrógeno - Óxido de nítrico - Óxido nitroso
Octafluorocyclobutane	HALOCARBON C318			
Octafluoropropane	- HALOCARBON R218			
OXYGEN	O ₂	OXYGENE	SAUERSTOFF	OXÍGENO
Oxirane	ETHYLENE OXIDE			
Isopentene	3- METHYLBUTENE-I			
Perfluorobutene-2	HALOCARBON R1318			

English name	Formula and Synonym(s)	French name Synonym (s)	German name and synonym(s)	Spanish name and synonym(s)
Perfluoroethane	HALOCARBON R116			
Perfluoropropane	HALOCARBON R218			
Perfluoropropene	HALOCARBON R1216			
PHOSGENE	COCl ₂ Carbonyl chloride	CHLORURE DE CARBONYLE - Oxychlorure de carbone - Phosgène	PHOSGEN - Chlorkohlenoxid - Kohlenoxidchlorid	CLORURO DE CARBONILO - Oxícloruro de carbono - Fosgeno
PHOSPHINE	PH ₃ Hydrogen phosphide	PHOSPHINE - Hydrogène phosphoré - Phosphure d'hydrogène	PHOSPHORWASS ERSTOFF - Phosphin	FOSFINA - Hidrógeno fosforado - Fosfuro de hidrógeno
PHOSPHORUS PENTA- FLUORIDE	PF ₅	PENTAFLUORUR E DE PHOS- PHORE	PHOSPHORPENTA FLUORID	PENTAFLUORURO DE FÓSFORO
PHOSPHORUS TRI- FLUORIDE	PF ₃			
PROPADIENE	C ₃ H ₄ Allene	PROPADIENE	PROPADIEN - Allen	PROPADIENO - Aleno
PROPANE	C ₃ H ₈	PROPANE	PROPAN	PROPANO
Propene	PROPYLENE			
PROPYLENE	C ₃ H ₆ - Propene	PROPYLENE - Propène	PROPEN - Propylen	PROPILENO - Propeno
1,2-PROPYLENE OXIDE	C ₃ H ₆ O - Propylene oxide - Epoxy propane - Methyloxirane	OXYDE DE PROPYLENE	PROPYLENOXID	ÓXIDO DE PROPILENO
Propyne	METHYL ACETYLENE			
SELENIUM HEXAFLUORIDE	SeF ₆		SELENHEXAFLUO RID	
Selenium hydride	HYDROGEN SELENIDE			
SILANE	SiH ₄ - Silicon tetrahydride	MONOSILANE - Silane - Hydrogène silicié - Tétrahydrure de silicium	SILICIUMWASSER STOFF - Silan - Monosilan - Silicomethan	SILANO - Hidrógeno siliciado - Tetrahidruo de silicio - Monosilano
SILICON TETRACHLORIDE	SiCl ₄	TETRACHLORUR E DE SILICIUM - Tetrachlorosilane	SILICIUM TETRACHLORID	TETRACLORURO DE SILICIO
SILICON TETRAFLUORIDE	SiF ₄	TETRAFLUORUR E DE SILICIUM	SILICIUM TETRAFLUORID	TETRAFLUORURO DE SILICIO
Silicon tetrahydride	SILANE			
STIBINE	SbH ₃ - Hydrogen antimonide - Antimony hydride	STIBINE - Antimoniure d'hydrogène - Hydrogène antimonié	ANTIMONWASSER STOFF - Stibin	ESTIBINA - Hidruo antimónico - Estibinamina
SULPHUR DIOXIDE	SO ₂ - Sulphurous acid anhydride	DIOXYDE DE SOUFRE - Anhydride sulfureux	SCHWEFELDIOXID - Schweflige Säure	DIÓXIDO DE AZUFRE - Anhídrido sulfuroso
SULPHUR HEXAFLUORIDE	SF ₆	HEXAFLUORURE DE SOUFRE	SCHWEFELHEXAF LUORID	HEXAFLUORURO DE AZUFRE
SULPHUR TETRAFLUORIDE	SF ₄	TETRAFLUORUR E DE SOUFRE	SCHWEFELTETRA FLUORID	TETRAFLUORURO DE AZUFRE
Sulphuretted hydrogen	HYDROGEN SULPHIDE			
Sulphurous acid anhydride	SULPHUR DIOXIDE			
SULPHURYL FLUORIDE	SO ₂ F ₂	FLUORURE DE SULFURYLE	SULFURYLFLUORID - Schwefeloxidfluorid	FLUORURO DE SULFURILO

English name	Formula and Synonym(s)	French name Synonym (s)	German name and synonym(s)	Spanish name and synonym(s)
Tetrafluoroethylene	HALOCARBON R1114			
TETRAFLUOROHYDRA ZIN	N ₂ F ₄	TETRAFLUOROHY DRAZINE	TETRAFLUORHYDR AZIN	TETRAFLURO HIDRAZINA
Tetrafluoromethane	HALOCARBON R14			
Trichlorofluoromethane	HALOCARBON R11			
TRICHLOROSILANE	SiHCl ₃ Silicichloroforme	TRICHLOROSILAN E	TRICHLORSILAN	TRICLOROSILANO
Trichlorotrifluoroethane	HALOCARBON R113			
Trifluoromethane	HALOCARBON R23			
Trifluorovinyl bromide	HALOCARBON R113B1			
TRIMETHYLAMINE	(CH ₃) ₃ N	TRIMETHYLAMINE	TRIMETYLAMIN	TRIMETILAMINA
TRIMETHYLSILANE	(CH ₃) ₃ SiH			
TUNGSTEN HEXAFLUORIDE	WF ₆ Wolfram hexafluoride	HEXAFLUORURE DE TUNGSTENE	WOLFRAM HEXAFLUORID	HEXAFLUORURO DE WOLFRAMIO - Hexafluoruro de tungsteno
VINYL BROMIDE	C ₂ H ₃ Br - Bromoethylene - Halocarbon R1140B1	MONOBROMOETH YLENE - Bromoéthylène - Ethylène bromé - Bromure d'éthylène - Bromure de vinyle - Réfrigérant 1140B1	BROMETHEN - Vinylbromid	MONOBROMOETILE NO - Bromo etileno - Bromuro de vinilo - Refrigerante 1140B1
VINYL CHLORIDE	C ₂ H ₃ Cl - Chloroethylene - Halocarbon R1140	MONOCHLOROET HYLENE - Chloroéthylène - Chloréthène - Chlorure de vinyle - Réfrigérant 1140	CHLORETHEN - Monochlorethylen - Vinylchlorid	MONOCHLOROETILE NO - Cloroeteno - Monocloroeteno - Cloroetileno - Cloruro de vinilo - Refrigerante 1140
VINYL FLUORIDE	C ₂ H ₃ F - Fluoro ethylene - Halocarbon R1141	MONOFLUROET HYLENE - Fluoroéthylène - Fluorure de vinyle - Réfrigérant 1141	FLUROETHEN - Fluorethylen - Monofluorethylen - R 1141	MONOFLUROETILE NO - Fluor etileno - Fluoruro de vinilo
VINYL METHYL ETHER	C ₃ H ₆ O - Methyl vinyl ether	ETHER METHYLVINYLIQU E - Methoxyéthylène - Oxyde de methyle et de vinyle	VINYLMETHYLETHE R - Methylvinylether	METIL VINIL ÉTER - Éter metilvinílico - Metoxietileno - Óxido de metilo y de vinilo
Vinylidene fluoride	HALOCARBON R1132a			
Wolfram hexafluoride	TUNGSTEN HEXAFLUORIDE			
XENON	Xe	XENON	XENON	XENÓN

Annex 3 - Index to gas names in English, French, Chinese, Korean and Japanese

GAS	Formula or synonym	French Gas Name or synonym	Chinese (Simplified) Gas Name	Chinese (Traditional) Gas Name	Korean Gas Name	Japanese Gas Name
Ammonia	NH ₃	AMMONIAC	氨	氨氣	암모니아	アンモニア
Argon	Ar	ARGON	氩	氩氣	아르곤	アルゴン
Arsine	AsH ₃	Hydrogen arsenide, arsenic tryhydride	砷烷(砷化氢)	砷化氫	아르신	アルシン
Boron Trichloride	BCl ₃	TRICHLORURE DE BORE	三氯化硼	三氯化硼	붕소 트리염화물	三塩化ホウ素
Boron Trifluoride	BF ₃	TRIFLUORURE DE BORE	三氯化硼	三氟化硼	삼불화 붕소	三フッ化ホウ素
Carbon Dioxide	CO ₂ , Carbonic acid anhydride	DIOXYDE DE CARBONE, anhydride carbonique	二氧化碳	二氧化碳	이산화 탄소	二酸化炭素
Carbon Monoxide	CO	MONOXYDE DE CARBONE- Oxyde de carbone	一氧化碳	一氧化碳	일산화 탄소	一酸化炭素
Chlorine	Cl ₂	CHLORE	氯	氯氣	염소	塩素
Chlorine Trifluoride	ClF ₃	TRIFLUORURE DE CHLORE	三氯化氯	三氟化氯	삼불화 염소	三フッ化塩素
Diborane	B ₂ H ₆	DIBORANE	乙硼烷	硼化氫	디보란	ジボラン
Dichlorosilane	SiH ₂ Cl ₂	DICHLOROSILANE	二氯硅烷(二氯氢硅)	二氯矽烷	디클로로실란	ジクロロシラン
Fluorine	F ₂	FLUOR	氟	氟	불소	フッ素
Germane	GeH ₄	Germanie, Monogermanie, Hydrogen germanie	锗烷	四氫化鍺	사수소화 게르마늄	ゲルマン
Helium	He	HELIUM	氦	氦氣	헬륨	ヘリウム
Hexafluoroethane (R116)	Perfluoroethane	THANE, Refrigerant 116	六氟乙烷	六氟乙烷	헥사플루오르에탄	六フッ化エタン
Hydrogen	H ₂	HYDROGENE	氢	氫氣	수소	水素
Hydrogen Bromide	HBr, Hydrobromic acid (anhydrous)	BROMURE D'HYDROGENE, Acide bromhydrique (anhydre), Gaz bromhydrique	溴化氢	溴化氫	브롬화 수소	臭化水素
Hydrogen Chloride	HCl, Hydrochloric acid	CHLORURE D'HYDROGENE, Acide chlorhydrique (anhydre), Gaz chlorhydrique	氯化氢	氯化氫	염화 수소	塩化水素
Hydrogen Selenide	H ₂ Se, Selenium hydride	SELENIURE D'HYDROGENE, hydrogene selenie	硒化氢	硒化氫	셀렌화 수소	セレン化水素
Hydrogen Sulphide	H ₂ S, Sulphuretted hydrogen	SULFURE D'HYDROGENE, Hydrogene sulfure	硫化氢	硫化氫	황화 수소	硫化水素
Methane	CH ₄	METHANE	甲烷	甲烷	메탄	メタン
Nitric Oxide	NO	MONOXYDE D'AZOTE, Bioxyde d'azote, Oxyde azotique	氧化氮	氧化氮	일산화 질소	酸化窒素
Nitrogen	N ₂	AZOTE	氮	氮氣	질소	窒素

GAS	Formula or synonym	French Gas Name or synonym	Chinese (Simplified) Gas Name	Chinese (Traditional) Gas Name	Korean Gas Name	Japanese Gas Name
Nitrogen Trifluoride	NF ₃	TRIFLUORURE D'AZOTE	三氟化氮	三氟化氮	삼불화 질소	三フッ化窒素
Nitrous Oxide	N ₂ O, Laughing gas	PROTOXYDE D'AZOTE, Hemioxyde d'azote, Oxyde azoteux	氧化亚氮(笑气)	氧化亞氮(笑氣)	아산화 질소	亜酸化窒素
Oxygen	O ₂	OXYGENE	氧	氧氣	산소	酸素
Phosphine	PH ₃ , Hydrogen phosphide	PHOSPHINE, Hydrogène phosphoré, Phosphure d'hydrogène	磷烷	磷化氫	포스핀	ホスフィン
Silane	SiH ₄ , Silicon tetrahydride	MONOSILANE, Silane, Hydrogène silicié, Tétrahydure de silicium	硅烷	矽甲烷	실란	モノシラン
Silicon Tetrafluoride	SiF ₄	TETRAFLUORURE DE SILICIUM	四氟化硅	四氟矽烷	사불화 규소	四フッ化ケイ素
Sulphur Hexafluoride	SF ₆	HEXAFLUORURE DE SOUFRE	六氟化硫	六氟化硫	육불화 황	六フッ化イオウ
Tetrafluoromethane (R14)	HALOCARBON R14		四氟化碳	四氟甲烷	테트라플루오르메탄	四フッ化メタン
Trifluoromethane (R23)	HALOCARBON R23		三氟甲烷	三氟甲烷	트리플루오르메탄	三フッ化メタン
Tungsten Hexafluoride	WF ₆ , Wolfram hexafluoride	HEXAFLUORURE DE TUNGSTENE	六氟化钨	六氟化鎢	텅스텐헥사플루오르화물	六フッ化タングステン
Hydrogen Fluoride	HF, Hydrofluoric acid (anhydrous)	FLUORURE D'HYDROGENE, Acide fluorhydrique anhydre, Gaz fluorhydrique	氟化氢	氟化氫	불화수소	フッ化水素
Octafluoropropane (R218)	HALOCARBON R218	C ₃ F ₈ , Octafluoropropane, Perfluoropropane	八氟丙烷	八氟丙烷	Octafluoropropane 옥타플루오로프로판 ; (할로카본 218)	八フッ化プロパン